



# Table of Contents

## SENSORS

Introduction .....	3
Passive Sensor Selection Guide .....	4
Magnetic Sensor Selection .....	6
Calculation of Output Voltage .....	7
Passive Speed Sensors .....	8
Listed Passive Speed Sensors UL/CSA/ATEX/IEC/EX .....	18
Side Look Sensor .....	21
Hall Effect Sensors .....	23
RH & DH Series Active Sensor Selection Guide .....	24
RH Series, Zero Velocity / Magnetic .....	26
DH Series, Zero Velocity / Magnetic .....	32
BH Series, Bi-Directional, Dual Channel .....	37
BH Series Active Sensor Selection Guide .....	38
BH Series Continued .....	39
Digital Signal Distance Amplifier (DSDA) .....	42
Connectors and Cable Assemblies .....	44
Split Gears / Solid Gear .....	46
Tachometer Transducers .....	48
Sensor Mounting Brackets .....	50
Principles of Operation .....	51
Part Number Index .....	52

**AI-TEK INSTRUMENTS IS AN AS9100/ISO 9001 COMPANY**



## Speed Sensors

**AI-Tek Instruments** manufactures hundreds of different designs of speed sensors. This catalog lists the standard units we developed, based on years of design experience and knowledge, to provide you readily available products to solve your sensor solution to your speed control or indication needs. Many of the hundreds of **AI-Tek** speed sensors we produce are designed for special applications which allows us to offer a highly versatile and flexible product line.

Designed to meet severe industrial, automotive and aerospace environments, **AI-Tek** speed sensors, will provide reliable, around-the-clock operation for many years under adverse conditions. Our design engineers have paid particular attention to trouble areas such as vibration, shock, extreme temperatures, wet, oily and corrosive atmospheres. Many of our speed sensors are specifically designed for high temperature, high or low speeds, various targets or for precise accuracy and timing applications. **AI-Tek** uses primarily the two technologies of variable reluctance, and Hall effect to convert motion into an electronic signal. By selecting the best technology for a specific application we can assure years of reliable performance.

This catalog offers a variety of options readily available through our distributors. If you cannot find a catalog item to meet your specific requirements, please contact your area distributor with your specifics; there is probably an existing design which comes close to your requirements. As a world leader in producing quality speed sensors, **AI-Tek Instruments** will provide a superb price/performance ratio.

## Passive Magnetic Sensors

Control and protection circuits have relied on variable reluctance technology for years. With few components and no moving parts, the passive magnetic speed sensors can provide a signal from the inside of an aircraft engine at temperatures approaching 425°C or from the hub of an automobile wheel at high shock and vibration. The advantages of these sensors are:

- High reliability
- Simple installation
- Long life due to no moving parts or contacts
- Self powered operation
- Wide variety of shapes and sizes
- Easy alignment
- Can be designed for almost any environment

Due to their flexibility, you will find **AI-Tek** variable reluctance sensors in everything from low-cost consumer products to highly-accurate automotive engine ignition systems to flight-worthy aircraft engine controls.

*It is the customer's responsibility to determine whether the product is proper for customer's use and application.*

*The information contained herein is subject to change without notice. Refer to the factory for verification of any details.*

# Passive Sensor Selection Guide

Thread Size	Part Number	Output * Guarentee Voltage (P-P)	Termination	Thread Length (in)	Sensor Length (in)	Agency Approval	Temp Rating (deg C)	Page
3/4-20	70085-1010-405	9.4	Cable	2.75	4	X	-55 to 232	19
3/4-20	70085-1010-413	13.4	Wires	1.5	2.75	X	-65 to 100	18
3/4-20	70085-1010-005	13.4	Wires	1.875	3.125	X	-65 to 100	18
3/4-20	70085-1010-541	13.4	Cable	1.88	3.13	X	-40 to 220	19
3/4-20	70085-1010-542	13.4	Cable	2.75	4	X	-40 to 220	19
3/4-20	70085-1010-327	13.4	Wires	2.75	4	X	-65 to 100	18
3/4-20	70085-1010-540	13.4	Cable	4	5.25	X	-40 to 220	19
3/4-20	70085-1010-328	13.4	Wires	4	5.25	X	-65 to 100	18
3/4-20	70085-1010-543	13.4	Cable	6	7.25	X	-40 to 220	19
3/4-20	70085-1010-414	13.4	Wires	6	7.25	X	-65 to 100	18
3/4-20	70085-3030-222	13.4	Cable	2.75	4	X	-65 to 95	20
M16 x 1.5	70085-1010-425	4.9	Connector	3	4.125		-55 to 107	12
M16 x 1.5	70085-3030-235	13.4	Cable	1.5	2.75	X	-65 to 95	20
M16 x 1.5	70085-3030-237	13.4	Cable	1.5	2.75	X	-65 to 95	20
5/8-18	70084-1713-111	13.4	Connector	1.125	2.5		-40 to 150	11
5/8-18	70085-1010-001	3.4	Connector	1.125	2.25		-55 to 107	8
5/8-18	70085-1010-003	3.4	Connector	2.625	3.75		-55 to 107	8
5/8-18	70085-1010-018	3.4	Connector	3.625	4.75		-55 to 107	8
5/8-18	70085-1010-118	3.4	Connector	5	6.125		-55 to 107	8
5/8-18	70085-1010-002	12.9	Connector	1.125	2.25		-55 to 107	8
5/8-18	70085-1010-175	12.9	Connector	2.625	3.75		-55 to 107	8
5/8-18	70085-1010-026	12.9	Connector	3.625	4.75		-55 to 107	8
5/8-18	70085-1010-408	12.9	Connector	5	6.125		-55 to 107	8
5/8-18	70085-1010-028	21.5	Connector	1.437	2.53		-70 to 107	9
5/8-18	70085-1010-004	4.3	Wires	1.125	2.125		-70 to 107	9
5/8-18	70085-1010-469	4.3	Wires	2.750	3.75		-70 to 107	9
5/8-18	70085-1010-131	15.1	Cable	1.687	1.687		-55 to 107	10
5/8-18	70085-1010-214	15.1	Cable	2.937	2.937		-55 to 107	10
5/8-18	70085-1010-078	3.4	Wires	1.812	1.812		-55 to 107	10
5/8-18	70085-1010-137	3.4	Wires	2.937	2.937		-55 to 107	10
5/8-18	70085-1010-220	12.8	Wires	2.937	2.937		-55 to 107	11
5/8-18	70085-1010-421	4.9	Connector	2.475	3.6		-55 to 107	12
5/8-18	70085-1010-424	4.9	Connector	4.493	5.618		-55 to 107	12
5/8-18	70085-1010-081	13.4	Wires	1.5	2.75	X	-65 to 100	18
5/8-18	70085-1010-544	13.4	Cable	1.88	3.13	X	-40 to 220	19
5/8-18	70085-1010-411	13.4	Wires	1.875	3.125	X	-65 to 100	18
5/8-18	70085-1010-329	13.4	Wires	2.75	4	X	-65 to 100	18
5/8-18	70085-1010-330	13.4	Wires	4	5.25	X	-65 to 100	18
5/8-18	70085-1010-412	13.4	Wires	6	7.25	X	-65 to 100	18
5/8-18	70085-1010-404	13.4	Cable	1.5	2.75	X	-55 to 220	19
5/8-18	70085-1010-406	13.4	Cable	2.75	4	X	-55 to 220	19
5/8-18	70085-1010-417	13.4	Cable	4	5.25	X	-55 to 220	19
5/8-18	70085-1010-420	13.4	Cable	6	7.25	X	-55 to 220	19
5/8-18	70085-1010-403	9.4	Cable	1.5	2.75	X	-55 to 232	19
5/8-18	70085-1010-415	9.4	Cable	4	5.25	X	-55 to 232	19
5/8-18	70085-1010-416	9.4	Cable	6	7.25	X	-55 to 232	19
5/8-18	70085-3030-111	13.4	Cable	1.5	2.75	X	-65 to 95	20
5/8-18	70085-3030-112	13.4	Cable	2.75	4	X	-65 to 95	20
5/8-18	70085-3030-113	13.4	Cable	4	5.25	X	-65 to 95	20
5/8-18	70085-3030-114	13.4	Cable	6	7.25	X	-65 to 95	20
5/8-18	70085-3030-211	9.4	Cable	1.5	2.75	X	-65 to 95	20
5/8-18	70085-3030-212	13.4	Cable	2.75	4	X	-65 to 95	20
5/8-18	70085-3030-213	9.4	Cable	4	5.25	X	-65 to 95	20
5/8-18	70085-3030-214	9.4	Cable	6	7.25	X	-65 to 95	20
5/8-18	70085-8080-003	12.8	Wires	1.812	1.812		-55 to 107	11

\* Output is based on .030" air gap at 500 IPS

# Passive Sensor Selection Guide

Thread Size	Part Number	Output * Guarentee Voltage (P-P)	Termination	Thread Length (in)	Sensor Length (in)	Agency Approval	Temp Rating (deg C)	Page
3/8-24	70085-1010-007	1.6	Wires	0.812	1.252		-55 to 107	13
3/8-24	70085-1010-056	1.6	Wires	3.625	4.065		-55 to 107	13
3/8-24	70085-1010-086	3.6	Wires	0.812	1.252		-55 to 107	13
3/8-24	70085-1010-355	3.6	Wires	0.812	1.252		-55 to 107	13
3/8-24	70085-1010-041	2	Wires	0.812	1.252		-73 to 232	14
3/8-24	70085-1010-428	2	Wires	1.5	1.94		-73 to 232	14
3/8-24	70085-1010-458	2	Wires	3.625	4.065		-73 to 232	14
3/8-24	70085-1010-174	3.6	Wires	0.812	1.252		-65 to 220	14
3/8-24	70085-8080-001	4.2	Wires	1.5	1.5		-55 to 107	15
.375 no thd	70085-1010-314	4.2	Cable	1.375	1.375		-30 to 85	15
.375 no thd	70085-8080-004	4.2	Cable	2.5	2.5		-30 to 85	15
1/4-40	70085-1010-024	0.4	Wires	0.687	1		-73 to 232	16
1/4-40	70085-1010-472	0.4	Wires	0.687	1.187		-73 to 232	16
1/4-40	70085-1010-227	0.4	Wires	1.687	2		-73 to 232	16
10-32	70085-1010-037	0.6	Wires	0.5	0.5		-55 to 107	17
10-32	70085-1010-299	0.6	Wires	1.25	1.25		-55 to 107	17
10-32	70085-1010-182	0.3	Wires	0.5	0.5		-73 to 232	17
10.32	70085-1010-289	0.3	Wires	1.25	1.25		-73 to 232	17

\* Output is based on .030" air gap at 500 IPS

## Magnetic Sensor Selection

The following information is supplied for assistance in selecting the proper sensors for your particular applications. One of the fundamental questions to be answered is, "Will there be enough sensor output voltage at the lowest operating speed?"

The sensor output voltage depends on:

- Surface Speed - speed target passes pole piece
- Gap - distance between target and pole piece
- Target Size - geometric relationship of pole piece and target
- Load Impedance - connected to sensor

The surface speed of a gear depends upon its diameter and RPM. Surface speed is expressed in terms of inches per second (IPS).

$$\text{Surface Speed (IPS)} = \frac{\text{RPM} \times \text{Outside Dia. (in.)} \times \pi}{60}$$

There is an optimum pitch (or tooth size) to obtain the highest possible output from a sensor, but this is seldom necessary. Figure 4 illustrates the relationship of tooth size and spacing for optimum magnetic sensor output. Using a fine tooth gear, relative to a large pole piece diameter sensor, results in a lower generated voltage because the flux also passes into adjacent teeth, resulting in a lower total flux variation.

The relationship between pole piece diameter and gear pitch and its effect on the output of a sensor is described in Table A.

**Table A:** Relative Output Vs. Gear Pitch

Pole Piece Dia. (in)	Gear Pitch						
	8	12	16	20	24	32	48
.187	1.00	0.83	0.33	0.16	—	—	—
.106	1.41	1.41	1.27	1.00	0.70	0.28	0.07
.093	1.25	1.25	1.25	1.00	0.75	0.37	0.12
.062	0.95	1.07	1.00	1.00	0.92	0.90	0.36
.040	1.00	1.00	1.00	1.00	1.00	0.90	0.60

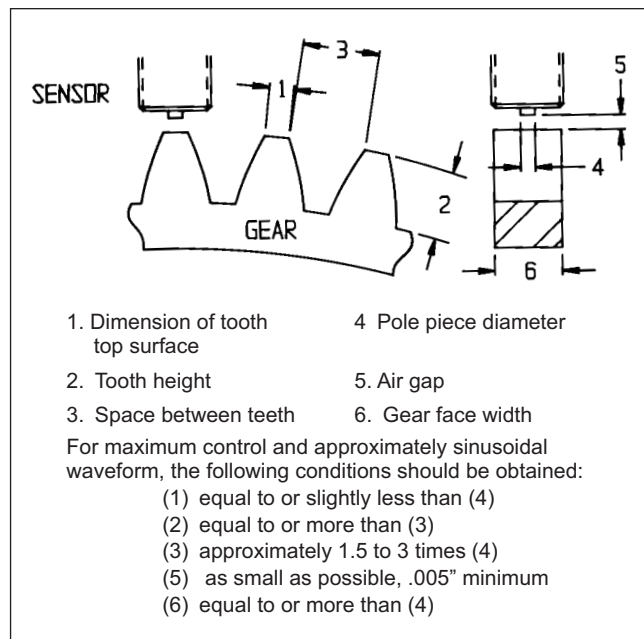

**Figure 4:** Sensor output as a function of gear tooth size.

The load impedance, with relation to the internal impedance of the sensor, dictates the amount of sensor output voltage that will be seen by that load. Magnetic sensors are designed with the lowest practical impedance consistent with providing maximum output. The load impedance should be high in relation to the impedance of the sensor to minimize the voltage drop across the coil and to deliver the maximum output to the load.

Most of the output voltages listed in this catalog are based on a load impedance of 100k ohms. To use a generality, the load impedance should be 10 times that of the sensor.

In order to assist you in selecting your sensor, **AI-Tek Instruments** has developed an output vs. speed curve for each sensor family. By looking at the application extremes of highest speed/lowest gap and lowest speed/highest gap, the full variation of sensor output can easily be determined. We also specify each family in two ways: **Standard** - minimum output voltage at 1000 IPS, 0.005 in. gap. **Guarantee Point** - minimum output voltage at 500 IPS, 0.030 in. gap. Sensors with .187" dia. pole piece are tested with an 8 D.P. gear, 100k ohms load; .106" dia. & smaller pole piece sensors are tested with a 20 D.P. gear, 100k ohms load. Sensors with connectors also use a 250 pf capacitor shunted across the load.

## Calculation of Output Voltage

Selection of the proper **AI-Tek** magnetic sensor may require the calculation of sensor output voltage to assure proper operation in your specific application. To assist in this area, let us consider the following typical application: Requirement is speed display with overspeed and underspeed control as well as 4-20 mA signal to a PLC. Speed range is 0-3600 RPM with low speed set point at 300 RPM, available shaft diameter for mounting a gear is 2.000 in. and a .030 in. air gap is ideal.

You have selected a Tachtrol 30, P/N T77630-10, with a 60T steel, split gear, P/N G79870-202-1901, and you are considering to use sensor P/N 70085-1010-001. The question is if the sensor has enough output voltage at 300 RPM.

We can list the following parameters:

- a. Tachtrol 30: Load impedance - 12k-ohms  
Sensitivity - 200 mV peak
- b. Split gear: Outside dia. - 5.166 in.  
D.P. - 12  
No. of Teeth - 60
- c. Sensor:  
Standard output voltage - 40V (P-P) min.  
Guarantee Point - 3.4V P-P min.  
D.C. Resistance - 130 ohms max.  
Typical inductance - 33 mH ref.

**Step 1:** Calculate surface speed of gear:

$$SS = \frac{RPM \times \text{Outside Dia.} \times \pi}{60} = \frac{300 \times 5.166 \times 3.14}{60} \quad SS = 81 \text{ IPS}$$

**Step 2:** Determine Peak-to-Peak output voltage:

Referring to the performance curves of sensor P/N 70085-1010-001 the min. output voltage is approx. 0.3 V (P-P) at 81 IPS and 0.030 in. gap. It is a fact that output voltage vs. surface speed is a near linear function; therefore, another method of determining output voltage is to set up a ratio using the guarantee point:

$$\frac{3.4V \text{ (P-P)}}{500 \text{ IPS}} = \frac{E}{81} \quad E = .55V \text{ (P-P)}$$

**Step 3:** Correction for pitch:

For a 0.106 in. pole piece dia. and a 12 D.P. gear the correction factor from Table A is 1 .41. (See pg. 5)

$$E_c = .55 \times 1.41 = .78 \text{ V (P-P)}$$

**Step 4:** Converting to peak voltage: Simply divide by 2.  $E_c = .78 \div 2 = .39V$  peak.

**Step 5:** Correction for load:

The .39V or 390mV sensor output voltage will be divided across the impedance of the load and sensor. The load impedance is 12000 ohms resistive. The impedance of the sensor has a resistive and inductive element. At low frequencies the inductive element is very small and can therefore be disregarded, leaving the max. DC resistance of 130 ohms for consideration.

The load correction factor ( $f_L$ ) can be expressed as:

$$(f_L) = \frac{Z \text{ (load)}}{Z \text{ (load)} + Z \text{ (sensor)}} = \frac{12000}{12130} = .99$$

$$E_c = .99 \times 390 = 386 \text{ mV peak}$$

The final adjusted value is 386 mV peak

As stated earlier, the sensitivity or threshold of the Tachtrol 30 is 200mV peak at the stated conditions, the selection of P/N 70085-1010-001 is acceptable.

By setting up ratios, you can determine that the minimum sensed speed is 155 RPM.

If the final value of  $E_c$  had been slightly less than 200 mV, a reduction of the air gap (from .030" to .025") would boost the output above 200 mV.

If it should be determined that the required sensor cannot be selected from the catalog models, the best procedure is to compile a list of all your requirements and contact your area distributor to assist you in the selection of the correct sensor.

## General Purpose

Ordering Part #	Thread Length (A)
70085-1010-001	1.125 (28.57)
70085-1010-003	2.625 (66.67)
70085-1010-018	3.625 (92.07)
70085-1010-118	5.000 (127.00)

(Select cable from group "A", see index)

### Performance Curves

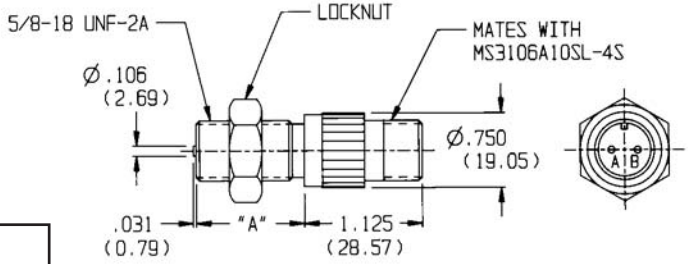
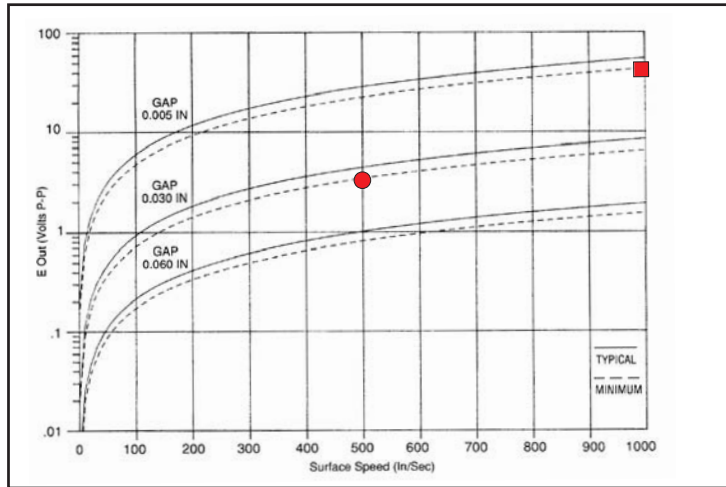

- Specifications:**
- Output Voltage (Standard): 40 V (P-P)
  - Output Voltage (Guarantee Point): 3.4 V (P-P)
  - DC Resistance: 130 ohms max.
  - Typical Inductance: 33 mH ref.
  - Output Polarity: Pin 'B' positive
  - Operating Temperature: -55 to +107°C
  - Net Weight: 5 oz. max.

## High Sensitivity

Ordering Part #	Thread Length (A)
70085-1010-002	1.125 (28.57)
70085-1010-175	2.625 (66.67)
70085-1010-026	3.625 (92.07)
70085-1010-408	5.000 (127.00)

(Select cable from group "A", see index)

### Performance Curves

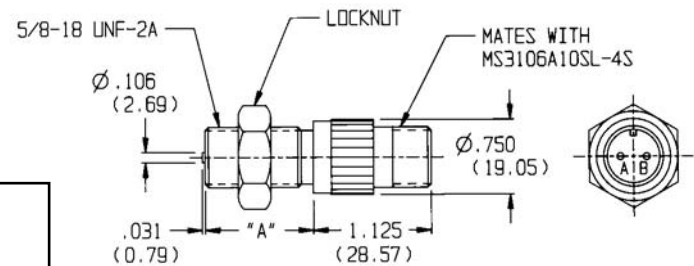
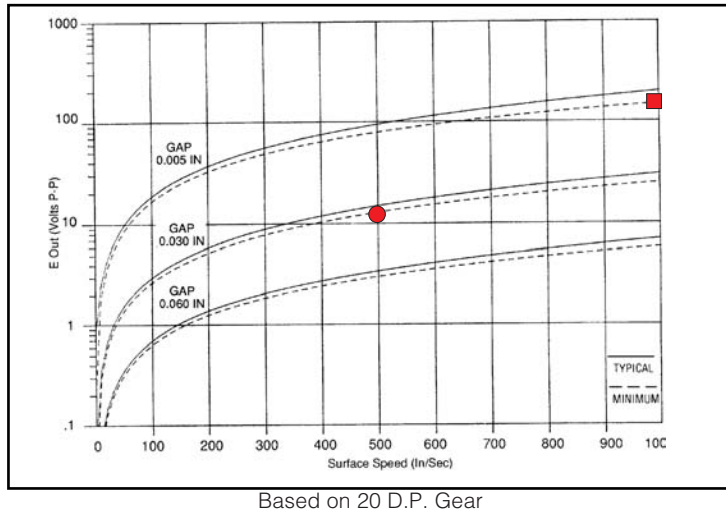

- Specifications:**
- Output Voltage (Standard): 150 V (P-P)
  - Output Voltage (Guarantee Point): 12.9 V (P-P)
  - DC Resistance: 1500 ohms max.
  - Typical Inductance: 360 mH ref.
  - Output Polarity: Pin 'B' positive
  - Operating Temperature: -55 to +107°C
  - Net Weight: 5 oz. max.

*Dimensions in inches and (mm).*



## Power Output

**Ordering Part #**                      **Thread Length (A)**  
 70085-1010-028                      1.437                      (36.50)  
 (Select cable from group "A", see index)

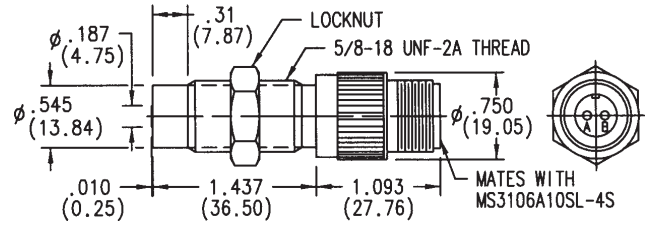

### Performance Curves

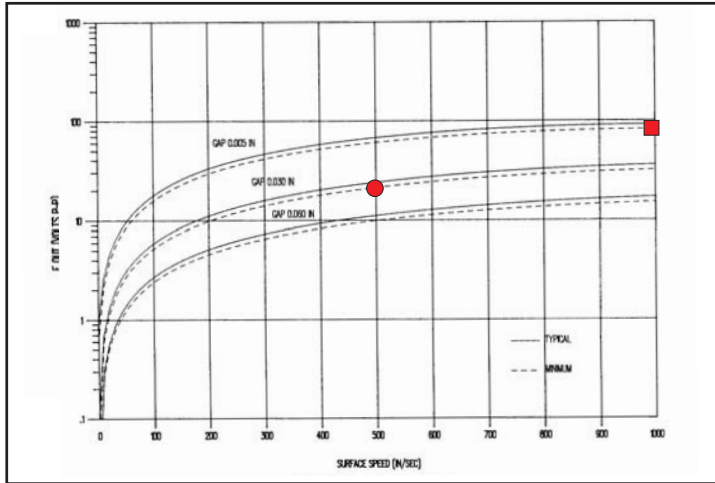

Based on 8 D.P. Gear

### Specifications:

- Output Voltage (Standard): 75 V (P-P)
- Output Voltage (Guarantee Point): 21.5 V (P-P)
- DC Resistance: 210 ohms max.
- Typical Inductance: 50 to 95 mH ref.
- Output Polarity: Pin "B" positive
- Operating Temperature: -73 to +107° C
- Net Weight: 2.2 oz. max.

## Conduit Fitting – General Purpose

**Ordering Part #**                      **Thread Length (A)**  
 70085-1010-004                      1.125                      (28.57)  
 70085-1010-469                      2.750                      (69.85)

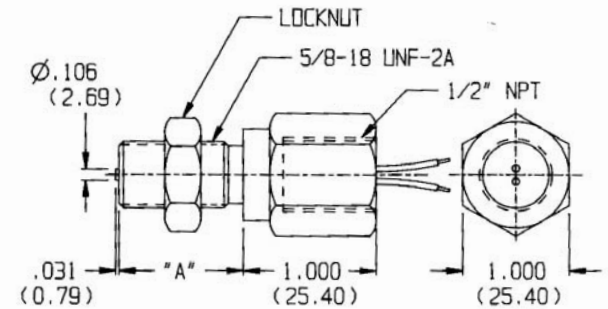

### Performance Curves

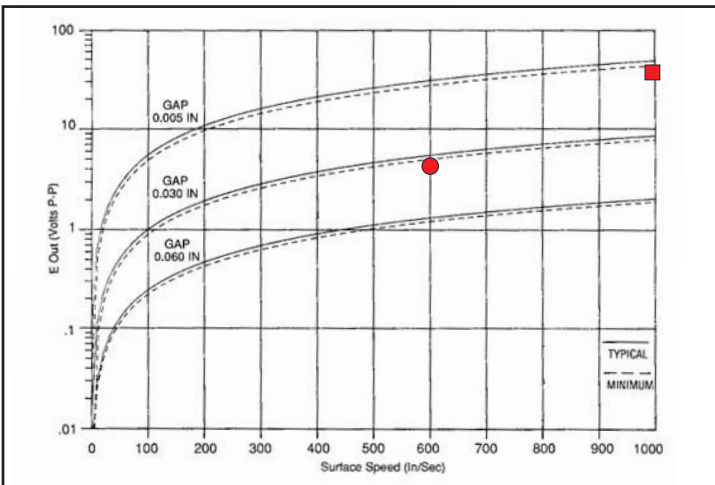

Based on 20 D.P. Gear

### Specifications:

- Output Voltage (Standard): 43 V (P-P)
- Output Voltage (Guarantee Point): 4.3 V (P-P)
- DC Resistance: 130 ohms max.
- Typical Inductance: 32-46 mH ref.
- Output Polarity: Red lead positive
- Operating Temperature: -73 to +107° C
- Lead length: 10 ft (3.05 m)
- Net Weight: 16 oz. max.

AI-Tek Instruments, Cheshire, CT USA

*Dimensions in inches and (mm).*

### Full Thread – Power Output

Ordering Part #	Thread Length (A)	
70085-1010-131	1.80	(45.72)
70085-1010-214	3.06	(77.72)

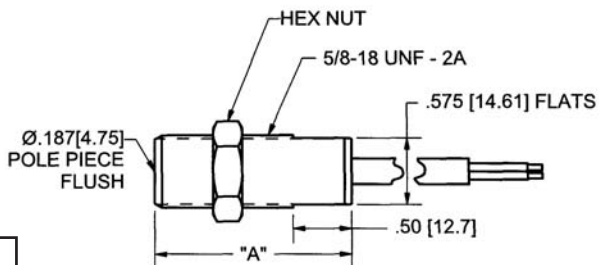

### Performance Curves

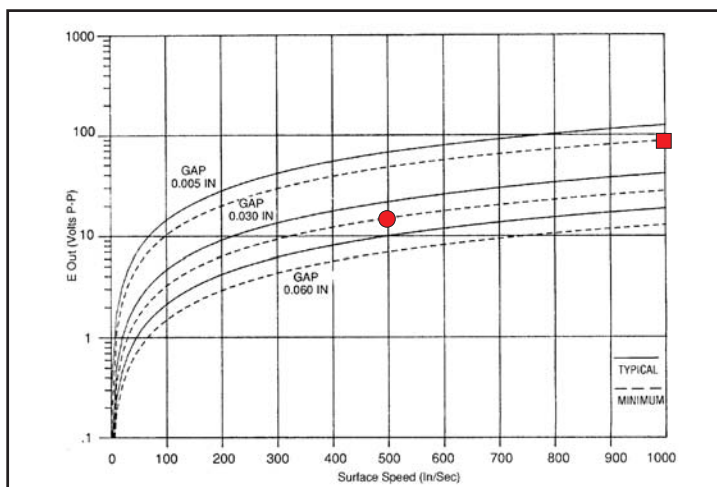

Based on 8 D.P. Gear

### Specifications:

- Output Voltage (Standard): 120 V (P-P)
- Output Voltage (Guarantee Point): 15.1 V (P-P)
- DC Resistance: 250 ohms max.
- Typical Inductance: 40-60 mH ref.
- Output Polarity: White lead positive
- Operating Temperature: -55 to +107° C
- Cable Length: 10 ft (3.05 m)
- Net Weight: 5 oz. max.

### Full Thread – General Purpose

Ordering Part #	Thread Length (A)	
70085-1010-078	1.80	(45.72)
70085-1010-137	3.06	(77.72)

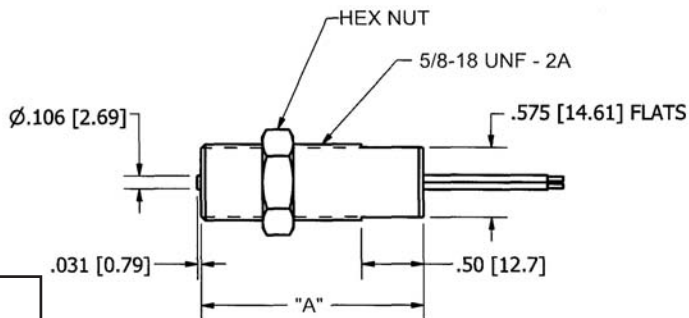

### Performance Curves

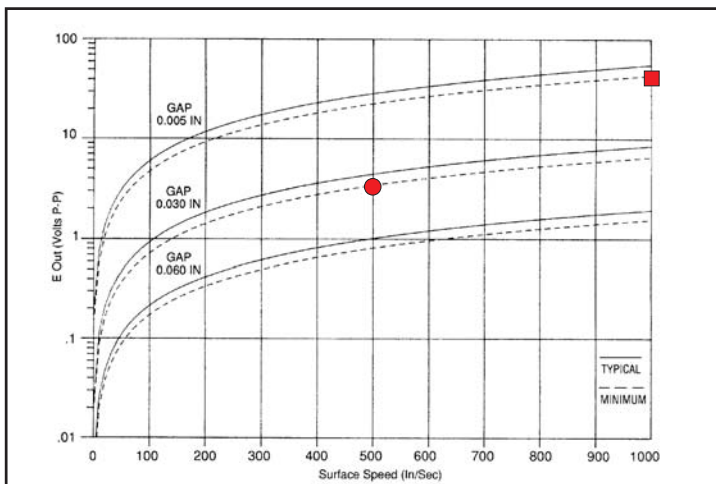

Based on 20 D.P. Gear

### Specifications:

- Output Voltage (Standard): 40 V (P-P)
- Output Voltage (Guarantee Point): 3.4 V (P-P)
- DC Resistance: 130 ohms max.
- Typical Inductance: 33 mH ref.
- Output Polarity: white lead positive
- Operating Temperature: -55 to +107° C
- Lead Length: -078, 12 in (30.5 cm)
- 137, 24 in (60.9 cm)
- Net Weight: 3 oz. max.

**Dimensions in inches and (mm).**

## Full Thread – High Sensitivity

Ordering Part #	Thread Length (A)
70085-8080-003	1.80 (45.72)
70085-1010-220	3.06 (77.72)

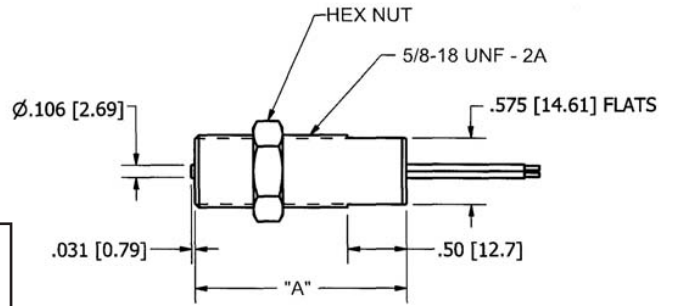

### Performance Curves

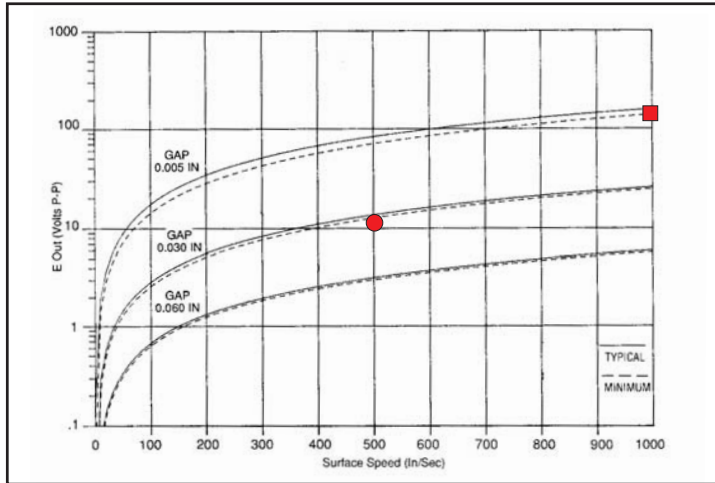

Based on 20 D.P. Gear

### Specifications:

- Output Voltage (Standard): 150 V (P-P)
- Output Voltage (Guarantee Point): 12.8 V (P-P)
- DC Resistance: 1430 ohms max.
- Typical Inductance: 500 mH ref.
- Output Polarity: White lead positive
- Operating Temperature: -55 to + 107°C
- Lead Length: -003, 12 in (30.5 cm)
- 220, 36 in (91.4 cm)
- Net Weight: 3 oz. max.

## Molded – High Sensitivity

Ordering Part #	Thread Length (A)
70084-1713-111	1.125 (28.57)

(Select cable from group "A", see index)

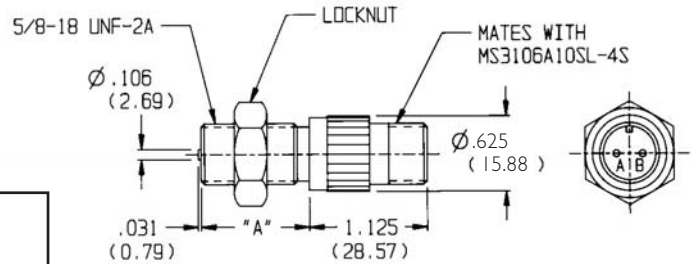

### Performance Curves

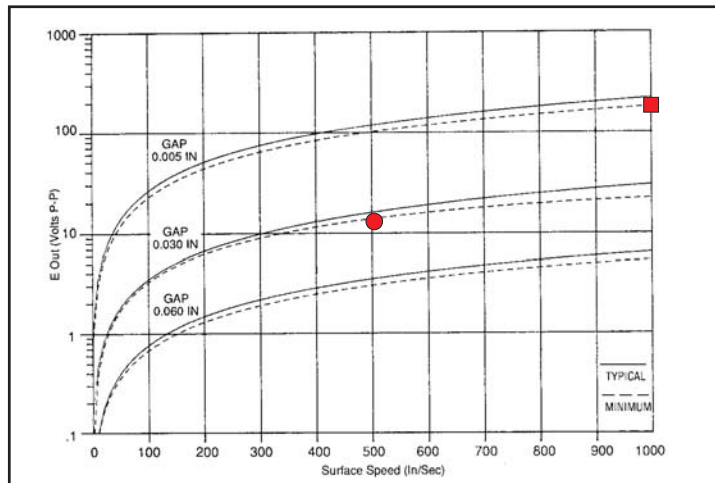

Based on 20 D.P. Gear

### Specifications:

- Output Voltage (Standard): 190 V (P-P)
- Output Voltage (Guarantee Point): 13.9 V (P-P)
- DC Resistance: 1200 ohms max.
- Typical Inductance: 400 mH ref.
- Output Polarity: Pin 'B' positive
- Operating Temperature: -40 to +150° C
- Net Weight: 2 oz. max.

Dimensions in inches and (mm).

**Molded**

Ordering Part #	Thread Length (A)
70085-1010-421	2.475 (62.87)
70085-1010-425	3.000 (76.20) * M16 x 1.5 Thd.
70085-1010-424	4.493 (114.12)

(Select cable from group "A", see index)

**Performance Curves \*\***

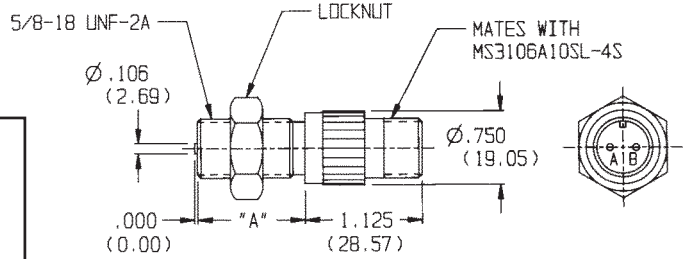
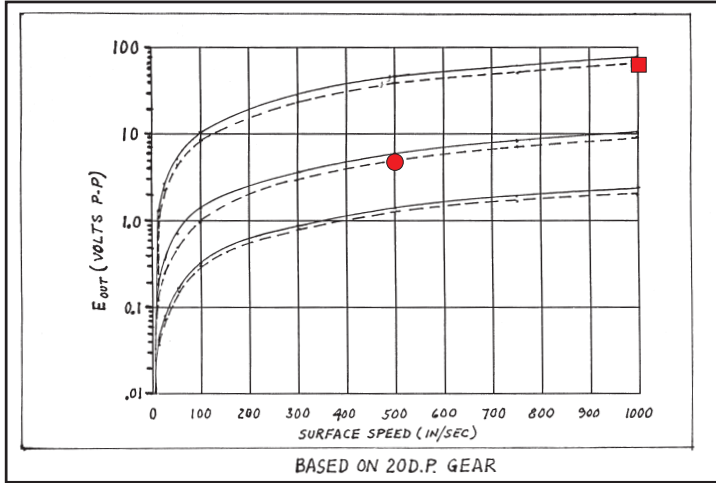

\* M16x1.5 Thd.

**Specifications:**

- Output Voltage (Standard): 63 V (P-P)
- Output Voltage (Guarantee Point): 4.9V (P-P)
- DC Resistance: 250 ohms max.
- Typical Inductance: 63 mH ref.
- Output Polarity: Pin 'B' positive
- Operating Temperature: -55 to +107° C
- Net Weight: 5 oz. max.

*Dimensions in inches and (mm).*

## General Purpose

Ordering Part #	Thread Length (A)
70085-1010-007	.812 (20.62)
70085-1010-056	3.625 (92.08)

### Performance Curves

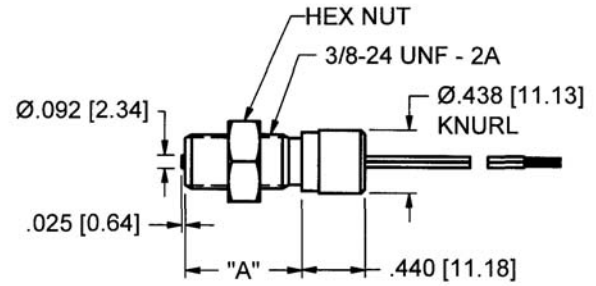
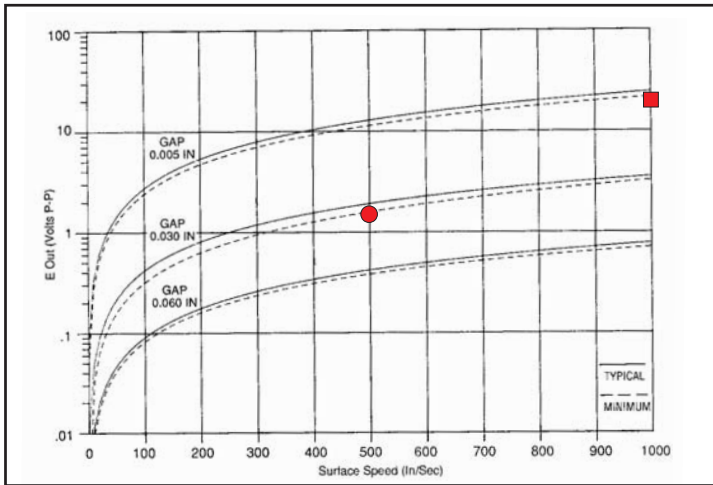

### Specifications:

- Output Voltage (Standard): 21 V (P-P)
- Output Voltage (Guarantee Point): 1.6 V (P-P)
- DC Resistance: 125 ohms max.
- Typical Inductance: 22 mH ref.
- Output Polarity: White lead positive
- Operating Temperature: -55 to +107°C
- Lead Length: 6 in (15.2 cm)
- Net Weight: 2 oz. max.

## High Sensitivity

Ordering Part #	Thread Length (A)
70085-1010-086	.812 (20.62)
70085-1010-355	.812 (20.62)

### Performance Curves

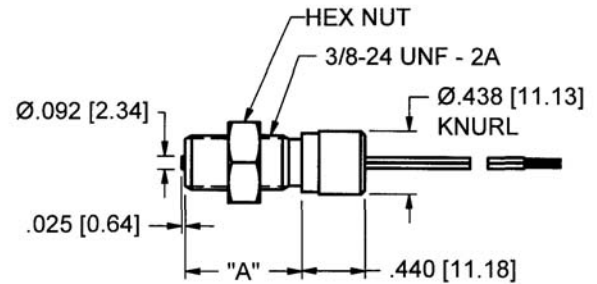
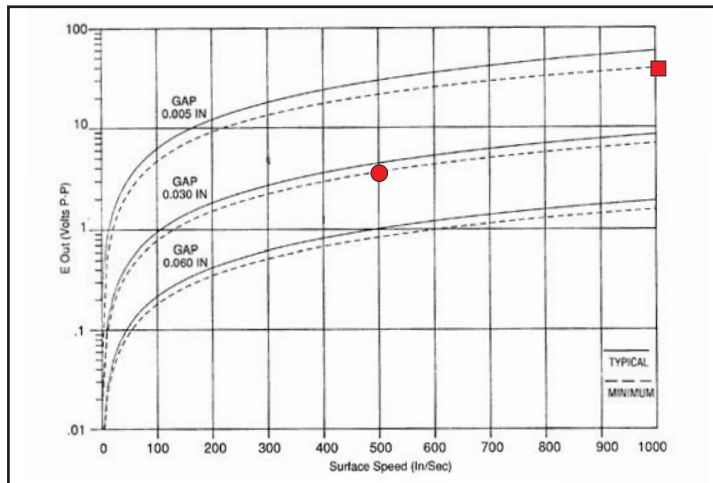

### Specifications:

- Output Voltage (Standard): 55 V (P-P)
- Output Voltage (Guarantee Point): 4.2V (P-P)
- DC Resistance: 960 ohms max.
- Typical Inductance: 125 mH ref.
- Output Polarity: White lead positive
- Operating Temperature: -55 to +107°C
- Lead Length: -086, 18 in (45.7 cm)
- Cable Length: -355, 40 in (101.6 cm)
- Net Weight: 2 oz. max.

AI-Tek Instruments, Cheshire, CT USA

Dimensions in inches and (mm).

## General Purpose - High Temperature

Ordering Part #	Thread Length (A)
70085-1010-041	.812 (20.62)
70085-1010-428	1.500 (38.10)
70085-1010-458	3.625 (92.08)

### Performance Curves

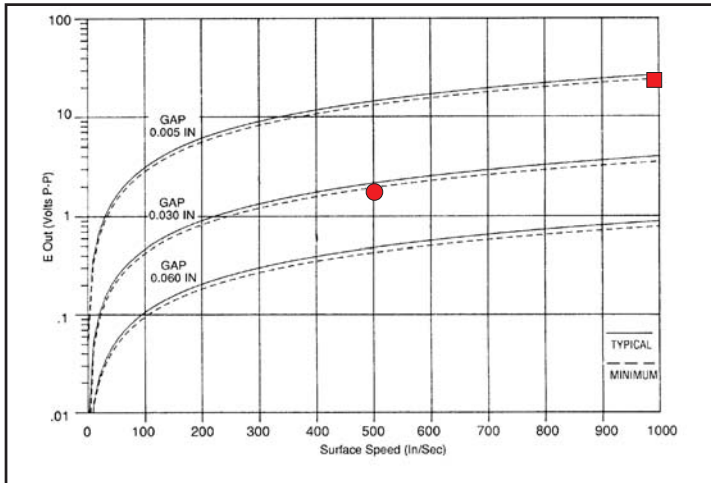

Based on 20 D.P. Gear

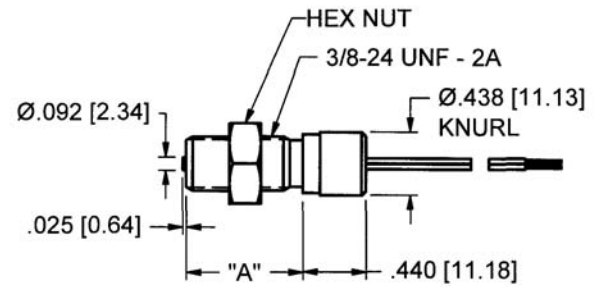

### Specifications:

- Output Voltage (Standard): 24 V (P-P)
- Output Voltage (Guarantee Point): 2.0 V (P-P)
- DC Resistance: 125 ohms max.
- Typical Inductance: 21 mH ref.
- Output Polarity: White lead positive
- Operating Temperature: -73 to +232°C
- Lead Length: 40 in (1 m)
- Net Weight: 2 oz. max.

## High Sensitivity - High Temperature

Ordering Part #	Thread Length (A)
70085-1010-174	.812 (20.62)

### Performance Curves

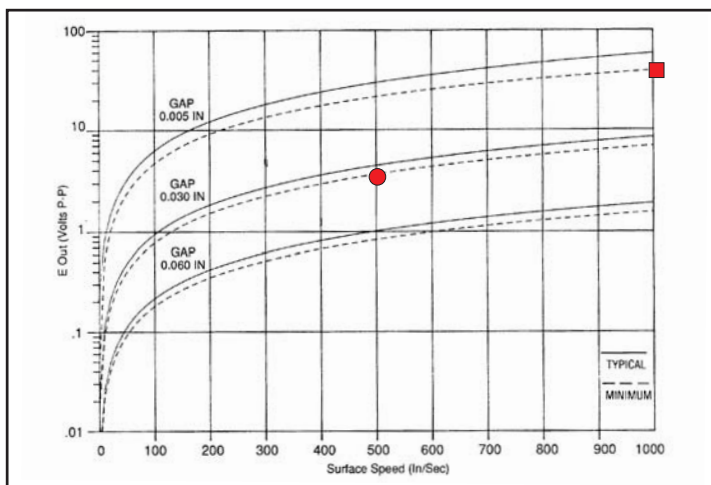

Based on 20 D.P. Gear

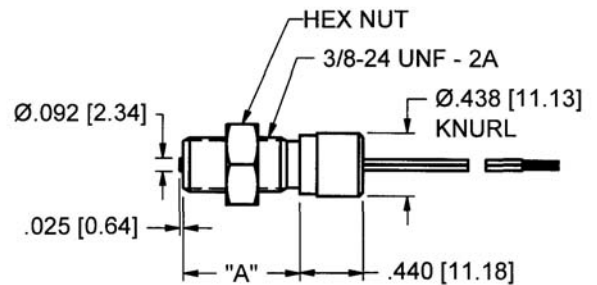

### Specifications:

- Output Voltage (Standard): 55 V (P-P)
- Output Voltage (Guarantee Point): 3.6V (P-P)
- DC Resistance: 705 ohms max.
- Typical Inductance: 150 mH ref.
- Output Polarity: White lead positive
- Operating Temperature: -65 to +220°C
- Cable Length: 60 in (1.5 m)
- Net Weight: 2 oz. max.

*Dimensions in inches and (mm).*

# Passive Speed Sensors

3/8 – 24 FAMILY

## Full Thread – High Sensitivity

Ordering Part #	Thread Length (A)	
70085-1010-120	1.250	(31.75)
70085-8080-001	1.500	(38.10)

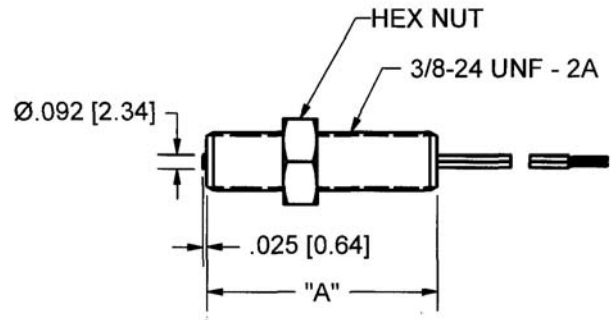

### Performance Curves

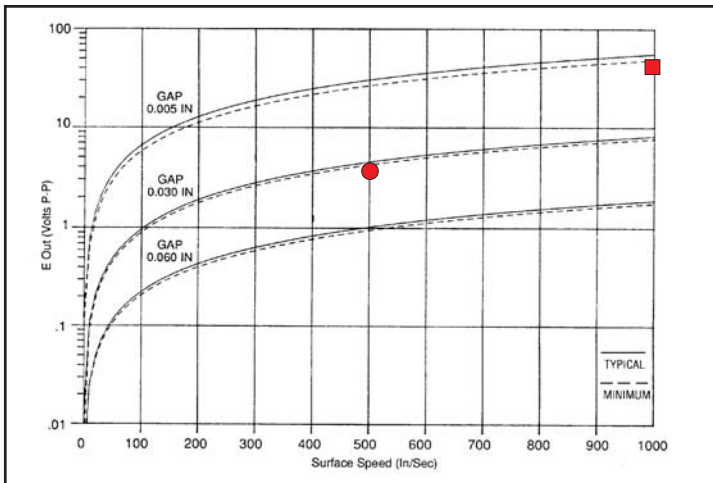

Based on 20 D.P. Gear

### Specifications:

- Output Voltage (Standard): 55 V (P-P)
- Output Voltage (Guarantee Point): 4.2 V (P-P)
- DC Resistance: 960 ohms max.
- Typical Inductance: 125 mH ref.
- Output Polarity: White lead positive
- Operating Temperature: -55 to +107°C
- Lead Length: 6 in (15.2cm)
- Net Weight: 1 oz. max.

## Smooth Body – High Sensitivity

Ordering Part #	Length (A)	
70085-1010-314	1.375	(34.93)
70085-8080-004	2.500	(63.50)

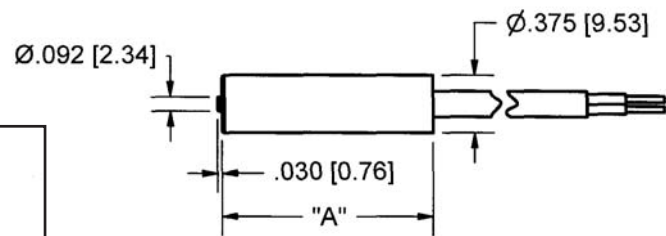

### Performance Curves

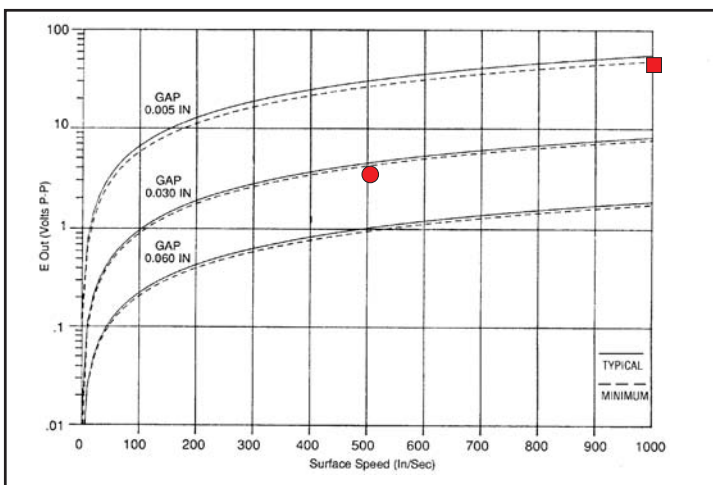

Based on 20 D.P. Gear

### Specifications:

- Output Voltage (Standard): 55 V (P-P)
- Output Voltage (Guarantee Point): 4.2 V (P-P)
- DC Resistance: 960 ohms max.
- Typical Inductance: 125 mH ref.
- Output Polarity: White lead positive
- Operating Temperature: -30 to +85°C
- Lead Length: -004, 6 in (15.2cm)
- Cable Length: -314, 10ft (3.05m)
- Net Weight: 3 oz. max.

AI-Tek Instruments, Cheshire, CT USA

Dimensions in inches and (mm).

## General Purpose - High Temperature

Ordering Part #	Thread	Length (A)	(B)
70085-1010-024	.687	(17.45)	.313 (7.95)
70085-1010-472 *	.687	(17.45)	.500 (12.70)
70085-1010-227	1.687	(42.85)	.313 (7.95)

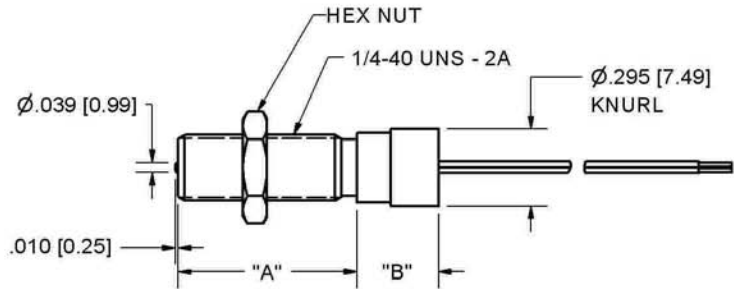

### Performance Curves

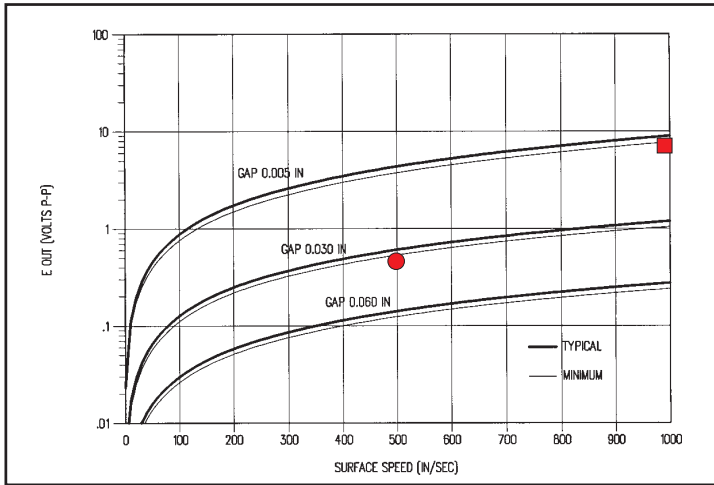

Based on 20 D.P. Gear

### Specifications:

- Output Voltage (Standard): 4.7 V (P-P)
- Output Voltage (Guarantee Point): 0.4 V (P-P)
- DC Resistance: 125 ohms max.
- Typical Inductance: 5-12 mH ref.
- Output Polarity: White lead positive
- Operating Temperature: -73 to 232°C
- Lead Length: 8 in (20.3 cm)
- Cable Length: -472, 60 in (1.5 m) \*
- Net Weight: 2 oz. max.

\* Egress is a 2-conductor, AWG #26, shielded, Teflon cable, with 3" long shrink tubing over housing and cable for extra protection. Extra locknut provided.

*Dimensions in inches and (mm).*



## High Sensitivity

Ordering Part #	Thread Length (A)
70085-1010-037	.500 (12.70)
70085-1010-299	1.250 (31.75)

### Performance Curves

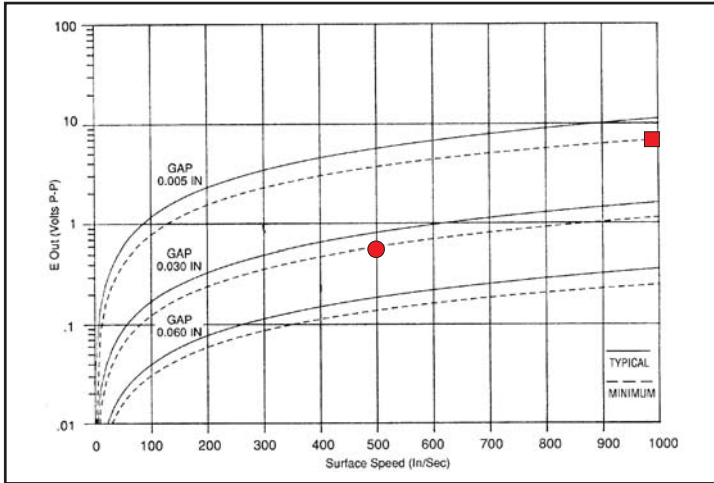

Based on 20 D.P. Gear

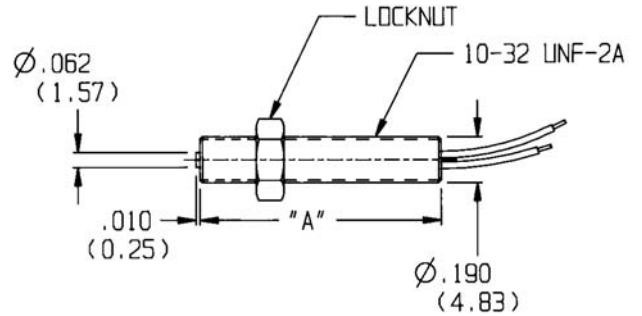

### Specifications:

- Output Voltage (Standard): 13 V (P-P)
- Output Voltage (Guarantee Point): .6 V (P-P)
- DC Resistance: 190 ohms max.
- Typical Inductance: 10 mH, ref.
- Output Polarity: White lead positive
- Operating Temperature: -55 to +107°C
- Lead Length: 18 in (45.7 cm)
- Net Weight: 1 oz. max.

## General Purpose – High Temperature

Ordering Part #	Thread Length (A)
70085-1010-182	.500 (12.70)
70085-1010-289	1.250 (31.75)

### Performance Curves

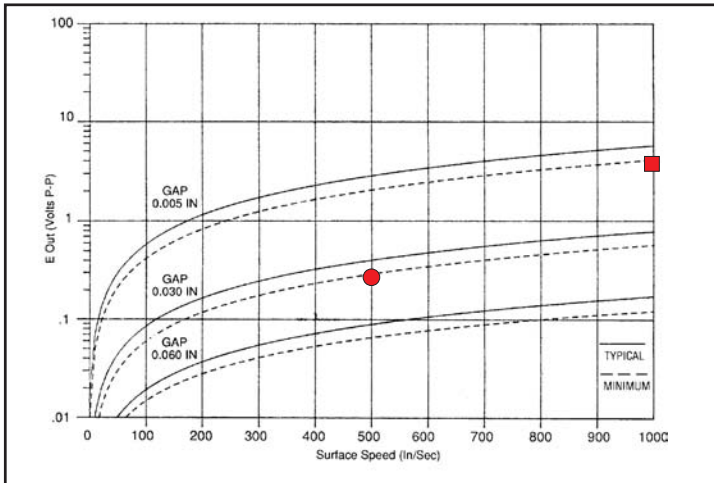

Based on 20 D.P. Gear

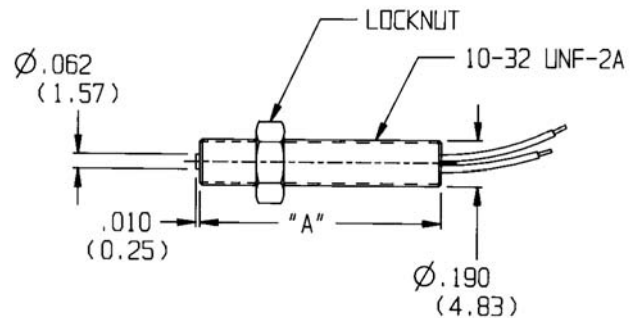

### Specifications:

- Output Voltage (Standard): 6 V (P-P)
- Output Voltage (Guarantee Point): .3 V (P-P)
- DC Resistance: 50 ohms max.
- Typical Inductance: 2 mH, ref.
- Output Polarity: White lead positive
- Operating Temperature: -73 to +150°C
- Lead Length: 18 in (45.7 cm)
- Net Weight: 1 oz. max.

AI-Tek Instruments, Cheshire, CT USA

Dimensions in inches and (mm).

## UL/ATEX/CSA Sensors

Ordering Part #	Thread Length (A)	
70085-1010-081	1.500	(38.10)
70085-1010-411	1.875	(47.63)
70085-1010-329	2.750	(69.85)
70085-1010-330	4.000	(101.60)
70085-1010-412	6.000	(152.40)

**Rating:** UL and CSA listed for hazardous locations. Class I, Div 1, Groups A, B, C & D; Class II, Div 1, Groups E, F, G. Temp Code T3C. ATEX Group II, Category 3G, Zone 2

### Performance Curves

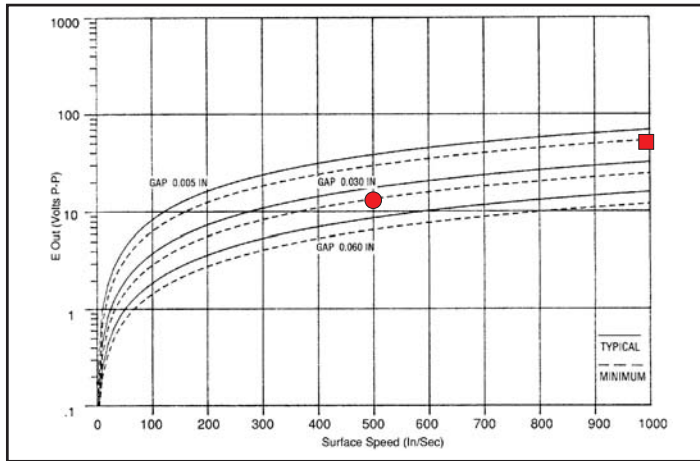

Based on 8 D.P. Gear

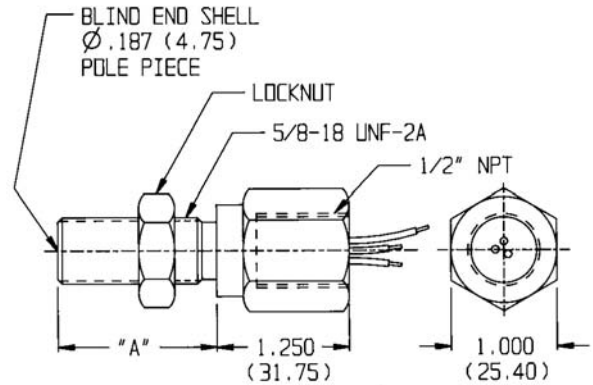

### Specifications:

- Output Voltage (Standard): 54 V (P-P)
- Output Voltage (Guarantee Point): 13.4 V (P-P)
- DC Resistance: 240 ohms max.
- Typical Inductance: 30 mH ref.
- Output Polarity: White lead positive
- Operating Temperature: -65 to 100°C
- Lead Length: 10 ft (3.05 m)
- Housing Ground: Green/Yellow Tracer
- Net Weight: 14 oz. max.

## UL/ATEX/CSA Sensors

Ordering Part #	Thread Length (A)	
70085-1010-413	1.500	(38.10)
70085-1010-005	1.875	(47.63)
70085-1010-327	2.750	(69.85)
70085-1010-328	4.000	(101.60)
70085-1010-414	6.000	(152.40)

**Rating:** UL and CSA listed for hazardous locations. Class I, Div 1, Groups A, B, C & D; Class II, Div 1, Groups E, F, G. Temp Code T3C. ATEX Group II, Category 3G, Zone 2

### Performance Curves

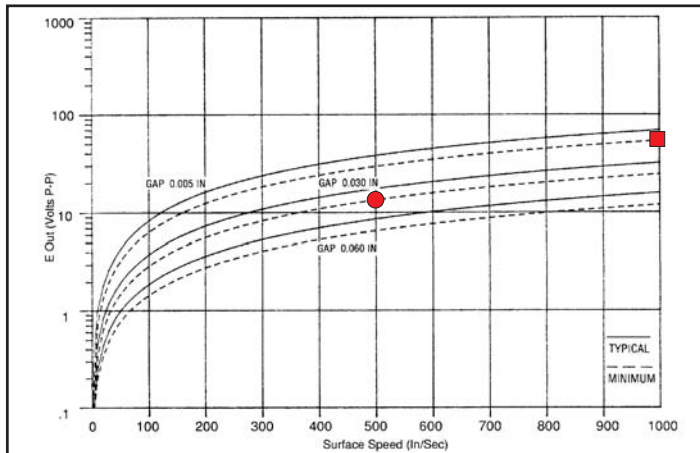

Based on 8 D.P. Gear

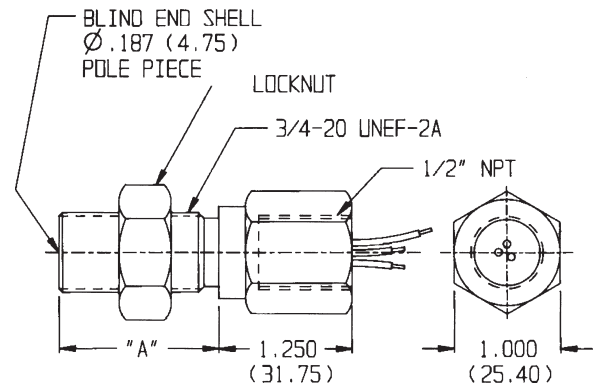

### Specifications:

- Output Voltage (Standard): 54 V (P-P)
- Output Voltage (Guarantee Point): 13.4 V (P-P)
- DC Resistance: 240 ohms max.
- Typical Inductance: 30 mH ref.
- Output Polarity: White lead positive
- Operating Temperature: -65 to +100°C
- Lead Length: 10 ft (3.05 m)
- Housing Ground: Green/Yellow Tracer
- Net Weight: 14 oz. max.

**Dimensions in inches and (mm).**

### FM / ATEX Sensors

Ordering Part #	Thread Length (A)	Thread Size (B)
70085-1010-404	1.500 (38.10)	5/8-18 UNF-2A
70085-1010-544	1.875 (47.63)	5/8-18 UNF-2A
70085-1010-406	2.750 (69.85)	5/8-18 UNF-2A
70085-1010-417	4.000 (101.60)	5/8-18 UNF-2A
70085-1010-420	6.000 (152.40)	5/8-18 UNF-2A
70085-1010-541	1.875 (47.63)	3/4-20 UNEF-2A
70085-1010-542	2.750 (69.85)	3/4-20 UNEF-2A
70085-1010-540	4.000 (101.60)	3/4-20 UNEF-2A
70085-1010-543	6.000 (152.40)	3/4-20 UNEF-2A

**Rating:** FM listed Intrinsically Safe, Class I, Division 1, Groups A, B, C, D; ATEX Group II, Category 3G, Zone 2.

### Performance Curves

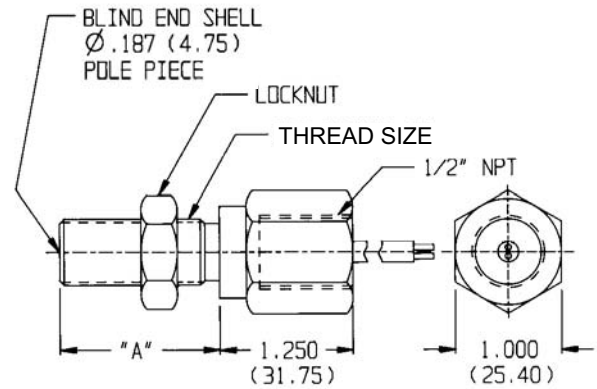
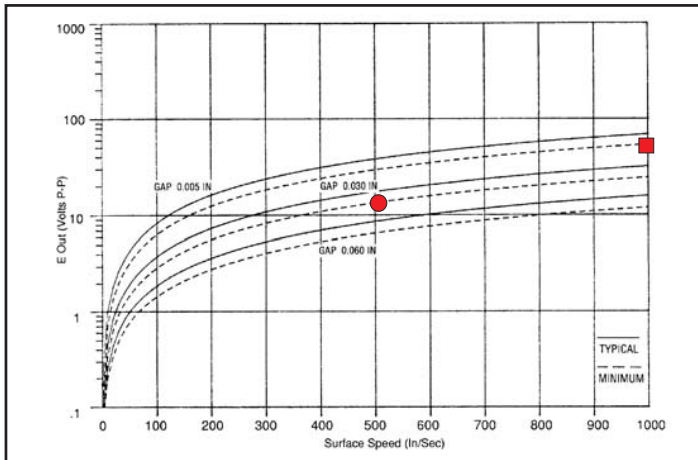

### Specifications:

- Output Voltage (Standard): 60V (P-P)
- Output Voltage (Guarantee Point): 13.4V (P-P)
- DC Resistance: 210 ohms max.
- Typical Inductance: 75 mH max.
- Output Polarity: White lead positive
- Operating Temperature: -55 to +220°C
- Cable Length: 15 ft. (4.57m)
- Net Weight: 16 oz. max.

### FM / ATEX Sensors

Ordering Part #	Thread Length (A)	Thread Size (B)
70085-1010-403	1.500 (38.10)	5/8-18 UNF-2A
70085-1010-415	4.000 (101.60)	5/8-18 UNF-2A
70085-1010-416	6.000 (152.40)	5/8-18 UNF-2A
70085-1010-405	2.750 (69.85)	3/4-20 UNEF-2A

**Rating:** FM listed Intrinsically Safe, Class I, Division 1, Groups A, B, C, D; ATEX Group II, Category 3G, Zone 2.

### Performance Curves

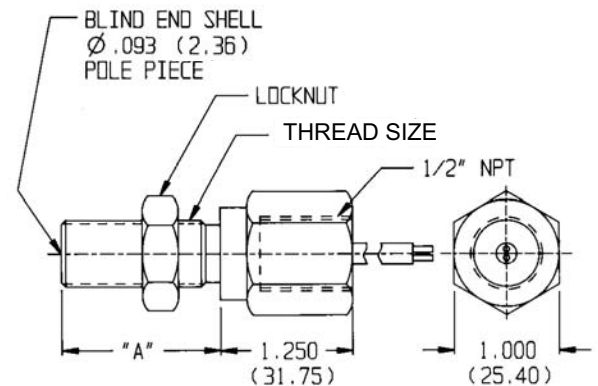
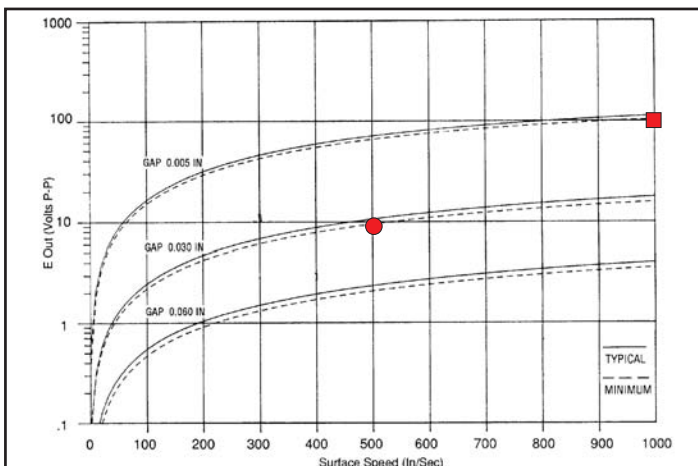

### Specifications:

- Output Voltage (Standard): 90 V (P-P)
- Output Voltage (Guarantee Point): 9.4 V (P-P)
- DC Resistance: 750 ohms max.
- Typical Inductance: 210 mH max.
- Output Polarity: White lead positive
- Operating Temperature: -55 to +232° C
- \*Mounting Thread: -0405, 3/4 - 20 UNEF-2A
- Cable Length: 15 ft (4.57 m)
- Net Weight: 16 oz. max.

## IEC EX Sensors

Ordering Part #	Thread Length (A)	Thread Size (B)	Cable Length (C)	Conduit Thread
70085-3030-111	1.500 (38.10)	5/8-18 UNF-2A	3 m	1/2 NPT
70085-3030-112	2.750 (68.85)	5/8-18 UNF-2A	3 m	1/2 NPT
70085-3030-113	4.000 (101.6)	5/8-18 UNF-2A	3 m	1/2 NPT
70085-3030-114	6.000 (152.4)	5/8-18 UNF-2A	3 m	1/2 NPT
70085-3030-211	1.500 (38.10)	5/8-18 UNF-2A	3 m	1/2 NPT
70085-3030-212	2.750 (68.85)	5/8-18 UNF-2A	3 m	1/2 NPT
70085-3030-213	4.000 (101.6)	5/8-18 UNF-2A	3 m	1/2 NPT
70085-3030-214	6.000 (152.4)	5/8-18 UNF-2A	3 m	1/2 NPT
70085-3030-222	2.750 (68.85)	5/8-18 UNF-2A	3 m	1/2 NPT
70085-3030-235	1.575 (40.00)	M16 x 1.5 6g	10 m	G 1/2
70085-3030-237	3.937 (100.0)	M16 x 1.5 6g	10 m	G 1/2

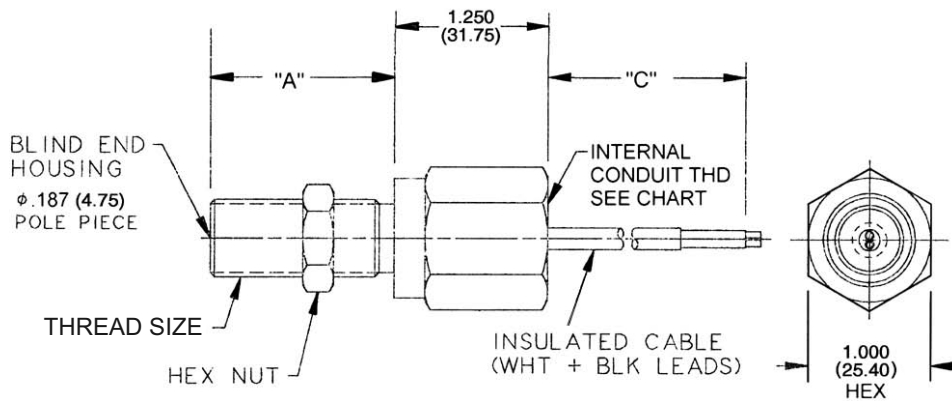

**Figure 1: Dimension Drawing**

**Rating:** ATEX and IEC Ex Equip Group II, Category 2G, Gas Group IIC, Zone 1

Sensor must be used with MTL 7764ac intrinsic barrier

User must install sensor in such a manner as to limit the output voltage to less than 12V Pk-Pk and a total energy of less than 26 microjoules

### Performance Curves

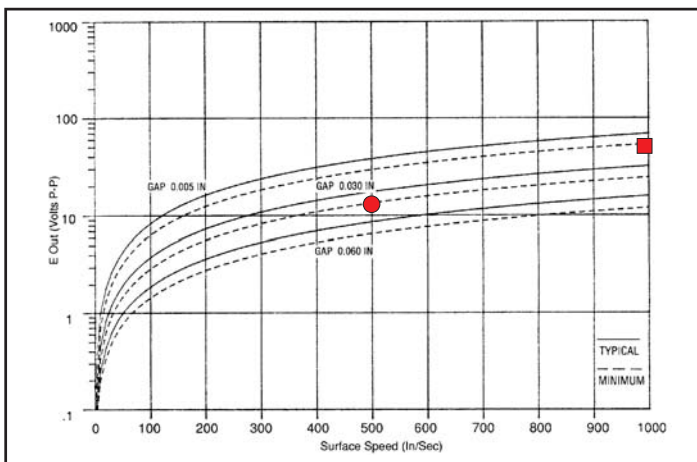

Based on 8 D.P. Gear

Available in a range of inch and metric thread lengths and sizes and cable lengths of 3 or 10 meters. Consult factory for additional details.

### Specifications:

- Output Voltage (Standard): 54 V (P-P)
- Output Voltage (Guarantee Point): 13.4 V (P-P)
- DC Resistance: 240 ohms max.
- Typical Inductance: 30 mH ref.
- Output Polarity: White lead positive
- Operating Temperature: -65 to 100°C
- Net Weight: 14 oz. max.

# AI-Tek Instruments, LLC Side Look Sensor

## Application: Used for Speed Take Off

The Side Look Sensor (SLS) has been developed by AI-Tek Instruments for Allison automatic transmissions for trucks ranging from light duty vans to over-the-road tractors. It is available for Allison AT, MT and HT transmissions. The new SLS improves on earlier designs developed for Allison to replace a mechanical speed system.

The SLS is a variable reluctance device that provides electronic transmission speed inputs to engine control systems and/or electronic dashboards. It mounts directly on the transmission and employs a unique magnet configuration that induces a magnetic field on the side of the sensor in the path of the rotating transmission gear. This system with its fewer mounting parts improves reliability, reduces weight and conserves space over the earlier designs.



The new SLS uses a molded, glass filled nylon body to protect the sensor in harsh, truck-operating environments. It replaces the old fly-lead design with an integral standard Packard connector, which eliminates the added extra connector cost of the old design. It is available in single and dual output versions.

The SLS is manufactured in the United States. AI-Tek Instruments Distributors stock the SLS for off-the-shelf maintenance, repair and overhaul (MRO) requirements.

## Outline and Mounting Dimensions

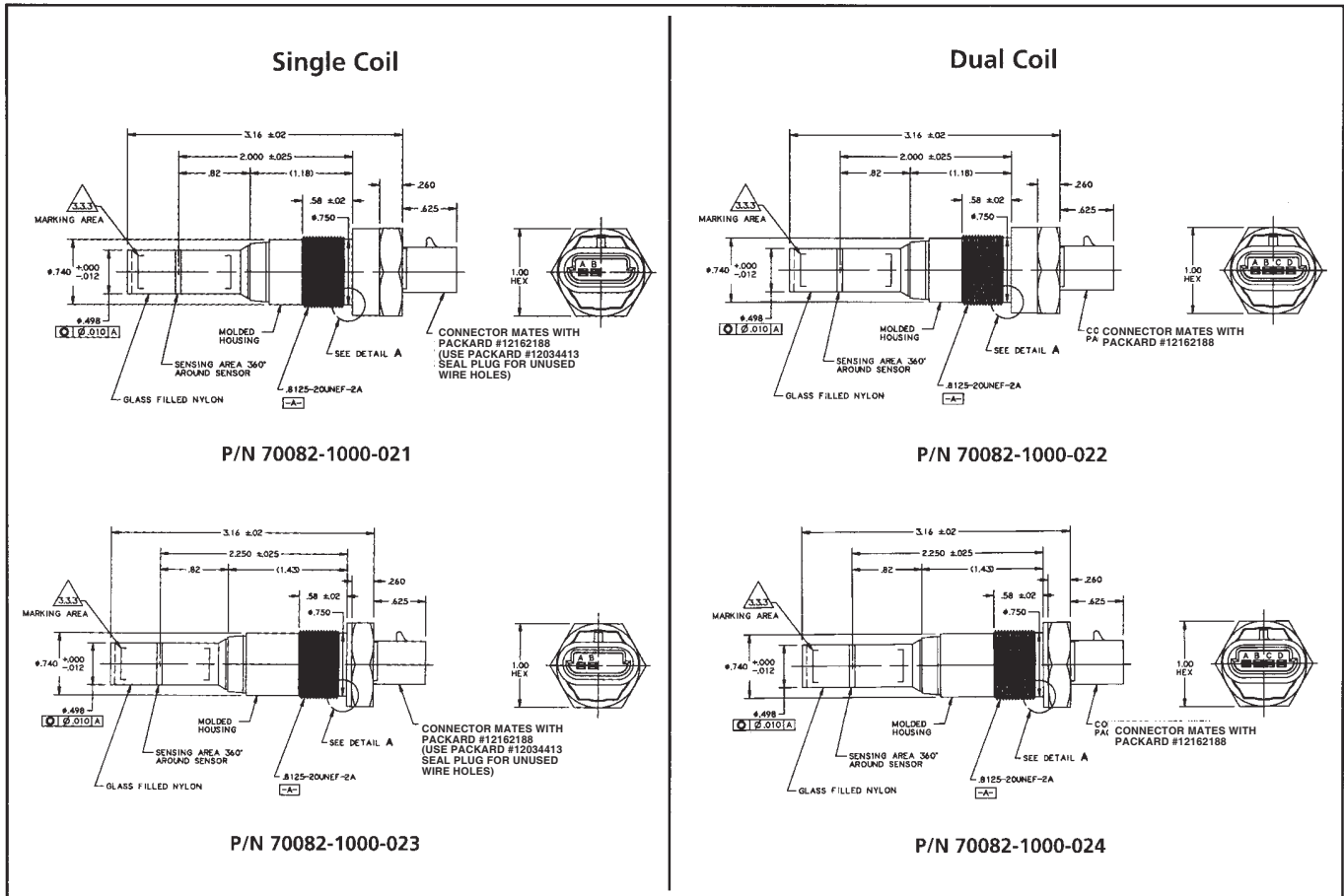

# Specifications

## Characteristics

### Physical

Weight: 55 gm typical.  
Body: Black, molded thermoplastic.

### Electrical

All measurements at 25°C.

#### Output:

Single Coil: .67 Volts peak-to-peak, A to B  
Dual Coil: .35 Volts peak-to-peak, A to B and C to D,  
Sensing a 16 tooth wheel, 2.208" diameter  
at 100 rpm and .040 inch air gap.

#### DC Resistance

Single Coil: 3.17K  $\pm$  10% ohms.  
Dual Coil: 1206  $\pm$  20% ohms each coil.

### Inductance

Single Coil: 2.25 H typical.  
Dual Coil: 620 mH typical.  
Dielectric: 1000 VAC between terminals (shorted together) and body for 10 seconds .  
.5 mA maximum leakage current.

### Environmental

#### Temperature

Operating Temperature: -40°C to 150°C.  
Storage Temperature: -40°C to 150°C.

#### Connector

Single Coil: Mates with Packard #12162188. (Use Packard #12034413 seal plug for unused wire holes.)  
Dual Coil: Mates with Packard #12162188.

**Single Coil**

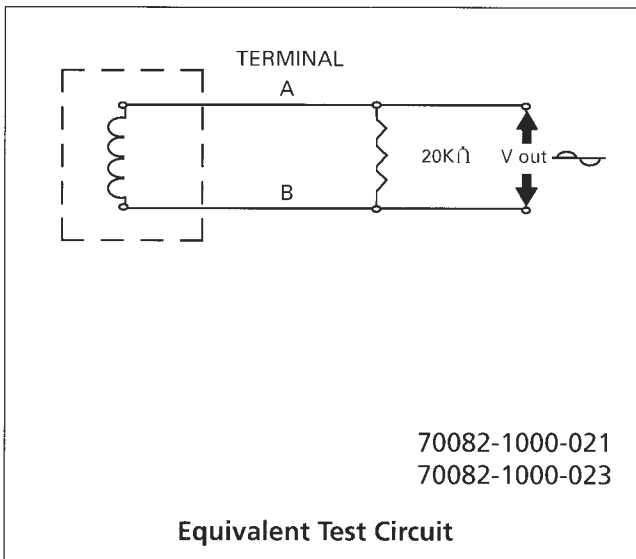

**Dual Coil**

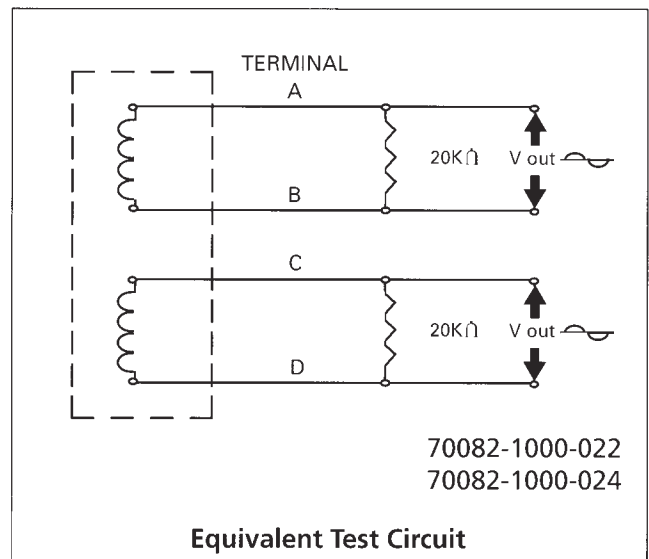

### Applications

P/N 70082-1000-021	AT, MT
P/N 70082-1000-022	AT, MT
P/N 70082-1000-023	HT
P/N 70082-1000-024	HT

## Hall Effect Sensors

AI-Tek has taken its years of experience of designing and manufacturing Hall Effect sensors for engine timing applications and has developed a line of durable products for industrial use.

With multiple standard variations we offer the widest range of standard catalog sensors to meet your various design needs. The design is flexible to easily meet all of your application requirements.

The Hall Effect sensor can sense each change in target movement, regardless of speed, from near zero to 15 kHz frequency range, generating a steady pulse train of frequency proportional to target speed. Typically, each time a gear tooth (or any ferrous discontinuity) passes in front of the sensor the output changes state. This type of sensor is known as a "P" type because it uses N-P-N transistor logic (as opposed to "N" type, which uses P-N-P transistor logic).

Key features to note are:

- Reverse voltage protection, to prevent damage if miswired
- Extended temperature range
- Wide range of supply voltage
- Two output options of Supply Tracking or TTL Compatible
- Rugged design meeting IEC 77 Standards (European Railroad Applications)

AI-Tek has (3) Series of Hall Effect Sensors: RH Series, DH Series and BH Series. Below is a quick reference chart of the features of each of the series.

<b>PERFORMANCE</b>	<b>RH SERIES</b> 1 Output Channel	<b>DH SERIES</b> 1 Output Channel	<b>BH SERIES</b> 2 Output Channels + Direction
Zero speed to 15kHz operation	<b>X</b>	<b>X</b>	<b>X</b>
Standard gear tooth sensing	<b>X</b>	<b>X</b>	<b>X</b>
Fine, 32 DP Capability		<b>X</b>	<b>X</b>
Single tooth / valley target		<b>X</b>	<b>X</b>
No installation alignment	<b>X</b>		
Extended airgap (0.100"+ for 12DP and coarser targets)		<b>X</b>	<b>X</b>
General noise immunity	<b>X</b>	<b>X</b>	<b>X</b>
EMI Hardened		<b>X</b>	<b>X</b>
High tolerance to target run-out		<b>X</b>	<b>X</b>
Self-calibrating		<b>X</b>	<b>X</b>
Direction Sensing			<b>X</b>
Lowest cost	<b>X</b>		

For applications that exceed 50 Ft (150 meters) go to page 42 for the DSDA, (Digital Signal Distance Amplifier).

*It is the customer's responsibility to determine whether the product is proper for customer's use and application.*

# RH & DH Series

## Active Sensor Selection Guide

Thread Size	Part Number	Supply Tracking or TTL	Termination	Thread Length (in)	Sensor Length (in)	Agency Approval	Page
3/4-20	DH1612-113	TTL	Cable	1.5	3.375		34
3/4-20	DH1622-113	ST	Cable	1.5	3.375		34
3/4-20	RH1612-013	TTL	Cable	1.5	3.375		27
3/4-20	RH1622-013	ST	Cable	1.5	3.375		27
3/4-20	DH1612-114	TTL	Cable	2.75	4.625		34
3/4-20	DH1622-114	ST	Cable	2.75	4.625		34
3/4-20	RH1612-014	TTL	Cable	2.75	4.625		27
3/4-20	RH1622-014	ST	Cable	2.75	4.625		27
3/4-20	DH1612-105	TTL	Connector	1.5	3.375		35
3/4-20	DH1622-105	ST	Connector	1.5	3.375		35
3/4-20	RH1612-005	TTL	Connector	1.5	3.375		28
3/4-20	RH1622-005	ST	Connector	1.5	3.375		28
3/4-20	DH1612-106	TTL	Connector	2.75	4.625		35
3/4-20	DH1622-106	ST	Connector	2.75	4.625		35
3/4-20	RH1612-006	TTL	Connector	2.75	4.625		28
3/4-20	RH1622-006	ST	Connector	2.75	4.625		28
3/4-20	DH1612-107	TTL	Connector	4	6.512		35
3/4-20	DH1622-107	ST	Connector	4	6.512		35
3/4-20	RH1612-007	TTL	Connector	4	6.512		28
3/4-20	RH1622-007	ST	Connector	4	6.512		28
3/4-20	DH1612-109	TTL	Wires	1.5	3.375		35
3/4-20	DH1622-109	ST	Wires	1.5	3.375		35
3/4-20	RH1612-009	TTL	Wires	1.5	3.375		28
3/4-20	RH1622-009	ST	Wires	1.5	3.375		28
3/4-20	DH1612-110	TTL	Wires	2.75	4.625		35
3/4-20	DH1622-110	ST	Wires	2.75	4.625		35
3/4-20	RH1612-010	TTL	Wires	2.75	4.625		28
3/4-20	RH1622-010	ST	Wires	2.75	4.625		28
3/4-20	RH1612-025	TTL	Cable	1.375	4.75	X	29
3/4-20	RH1612-026	TTL	Cable	1.5	3.375	X	29
3/4-20	RH1622-026	ST	Cable	1.5	3.375	X	29
3/4-20	RH1612-027	TTL	Cable	2.75	4.625	X	29
3/4-20	RH1622-027	ST	Cable	2.75	4.625	X	29



# RH & DH Series

## Active Sensor Selection Guide

Thread Size	Part Number	Supply Tracking or TTL	Termination	Thread Length (in)	Sensor Length (in)	Agency Approval	Page
5/8-18	DH1512-113	TTL	Cable	1.5	3.375		34
5/8-18	DH1522-113	ST	Cable	1.5	3.375		34
5/8-18	RH1512-013	TTL	Cable	1.5	3.375		27
5/8-18	RH1522-013	ST	Cable	1.5	3.375		27
5/8-18	DH1512-114	TTL	Cable	2.75	4.625		34
5/8-18	DH1522-114	ST	Cable	2.75	4.625		34
5/8-18	RH1512-014	TTL	Cable	2.75	4.625		27
5/8-18	RH1522-014	ST	Cable	2.75	4.625		27
5/8-18	DH1512-105	TTL	Connector	1.5	3.375		35
5/8-18	DH1522-105	ST	Connector	1.5	3.375		35
5/8-18	RH1512-005	TTL	Connector	1.5	3.375		28
5/8-18	RH1522-005	ST	Connector	1.5	3.375		28
5/8-18	DH1512-106	TTL	Connector	2.75	4.625		35
5/8-18	DH1522-106	ST	Connector	2.75	4.625		35
5/8-18	RH1512-006	TTL	Connector	2.75	4.625		28
5/8-18	RH1522-006	ST	Connector	2.75	4.625		28
5/8-18	DH1512-107	TTL	Connector	4	6.512		35
5/8-18	DH1522-107	ST	Connector	4	6.512		35
5/8-18	RH1512-007	TTL	Connector	4	6.512		28
5/8-18	RH1522-007	ST	Connector	4	6.512		28
5/8-18	DH1512-109	TTL	Cable	1.5	3.375		35
5/8-18	DH1522-109	ST	Cable	1.5	3.375		35
5/8-18	RH1512-009	TTL	Cable	1.5	3.375		28
5/8-18	RH1522-009	ST	Cable	1.5	3.375		28
5/8-18	DH1512-110	TTL	Cable	2.75	4.625		35
5/8-18	DH1522-110	ST	Cable	2.75	4.625		35
5/8-18	RH1512-010	TTL	Cable	2.75	4.625		28
5/8-18	RH1522-010	ST	Cable	2.75	4.625		28
5/8-18	RH1512-026	TTL	Cable	1.5	3.375	X	29
5/8-18	RH1522-026	ST	Cable	1.5	3.375	X	29
5/8-18	RH1512-027	TTL	Cable	2.75	4.625	X	29
5/8-18	RH1522-027	ST	Cable	2.75	4.625	X	29
5/8-18	DH1512-210	ST*	Cable	2.75	2.75		36
5/8-18	DH1522-210	ST*	Cable	2.75	2.75		36
3/8-32	RH1320-001	ST	Wires	1.63	1.63		31
3/8-32	RH1320-003	ST	Cable	1.63	1.63		31
3/8-24	RH1320-009	ST	Wires	1.63	1.63		31
3/8-24	RH1320-010	ST	Cable	1.63	1.63		31
3/8-24	RH1320-012	ST	Cable	3	3		31
3/8 Dia	RH1320-005	ST	Wires	—	—		31
3/8 Dia	RH1320-006	ST	Cable	—	—		31

\*NOTE: RTD Temperature Sensing Feature

## RH Series

### Zero Velocity - Magnetic Hall Effect Sensors - 5/8 and 3/4 Threads

#### Specifications

##### Power Supply

###### Power Supply Voltage:

4.5 - 24 Vdc

###### Power Supply Current:

50 mA maximum

##### Outputs

###### Output Voltage:

Essentially square wave fanout to 10 TTL inputs

###### TTL Compatible: (See Figure 1)

50% ±15% duty cycle

Logic 0: +.6 Vdc maximum

Logic 1: +4 to +4.6 Vdc @ 5mA

###### Supply Tracking: (See Figure 2)

50% ±15% duty cycle

Logic 0: +.6 Vdc maximum

Logic 1: 
$$V_O = \frac{V_S \times R_L}{R_L + 2.2k}$$

###### Output Impedance:

2.2K Ohms ±5%

###### Output Current:

20 mA sink maximum

###### Output Current - Short Circuit:

5 mA maximum with 10V power supply

###### Reverse Battery Voltage:

-30 Vdc

##### Mechanical

###### Target Frequency:

0 to 15 kHz

###### Target Air Gap:

.005 to .020 with a 24 diametral pitch gear

.005 to .030 with a 20 diametral pitch gear

.005 to .050 with a 12 diametral pitch gear

.005 to .075 with an 8 diametral pitch gear

##### Environmental

###### Operating Temperature:

-40°C to +125°C

###### Thermal Shock:

100 cycles air to air (-40° to +130°C)

1 min. ramp time with 30 min. soak

###### Salt Spray:

Per MIL-STD-202, method 201, test cond. B, 5% NaCl for 48 hrs. No visible corrosion.

###### Humidity:

92% RH@ 40°C for 90 hrs.

No visible corrosion.

###### Dielectric Strength:

Per MIL-STD-202, method 301, 1000 Vrms (60Hz) for 5 sec. leads to case. 1.0 mA max. leakage.

###### Insulation Resistance:

Per MIL-STD-202, method 302, 500 Vdc for 30 sec. leads to case. 100 mega-ohm min.

###### Vibration:

Per MIL-STD-202, resonant frequency search, sine method 204, test cond. C&D (20g); random method 214a, test cond. A&B (7.56g) for 15 min.

###### Shock:

Per MIL-STD-202, method 213b (sawtooth), test cond. H&I (1 00g, 6 ms), 3 shocks, mutually perpendicular planes

##### Materials

###### Housing:

300 series stainless steel

###### Leads:

AWG #24 Teflon, 200°C

###### Cable:

AWG #20 Irradiated cross-linked polyolefin, 125°C

Rotational alignment of sensing face is not required for optimum output signal.

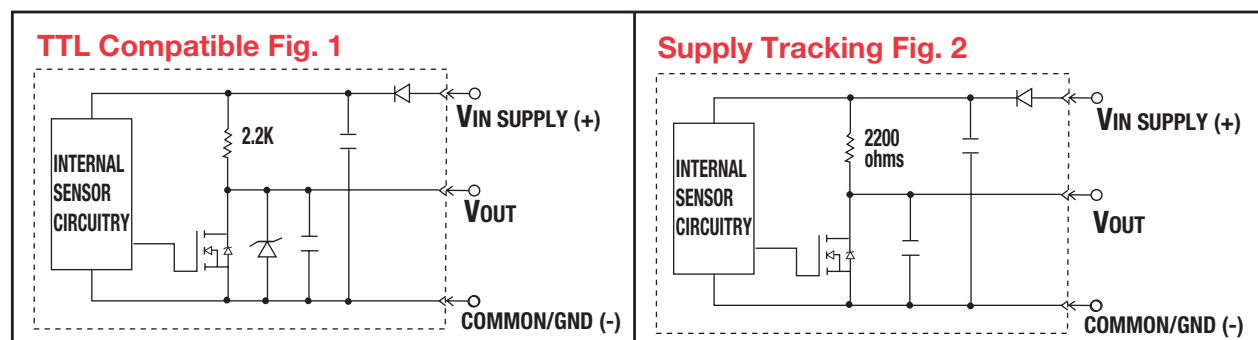

Note: Either output will work with any AI-Tek Tachometer.

## RH Series

### Zero Velocity - Magnetic Hall Effect Sensors - 5/8 and 3/4 Threads

#### Hex Body with Cable

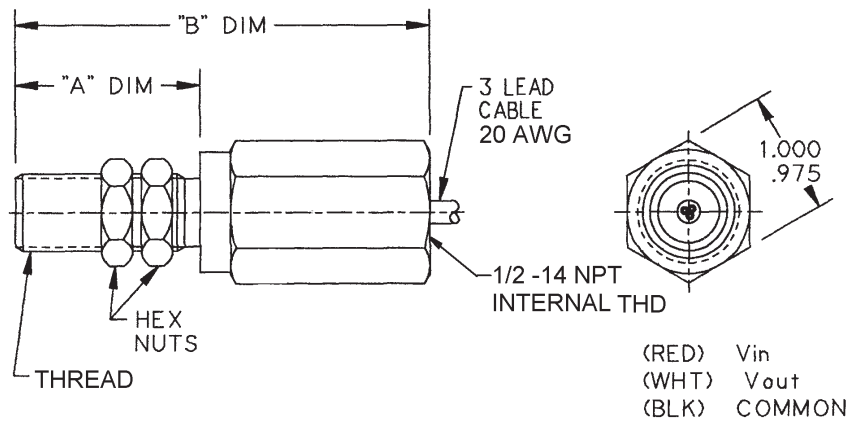

Part Num.	Thread	"A" Dimension	"B" Dimension	Cable Length	Output
RH1512-013	.625-18 UNF-2A	1.500 (38.100)	3.375 (85.725)	10 ft (3.05m)	TTL Compatible
RH1522-013	.625-18 UNF-2A	1.500 (38.100)	3.375 (85.725)	10 ft (3.05m)	Supply Tracking
RH1512-014	.625-18 UNF-2A	2.750 (69.850)	4.625 (117.475)	10 ft (3.05m)	TTL Compatible
RH1522-014	.625-18 UNF-2A	2.750 (69.850)	4.625 (117.475)	10 ft (3.05m)	Supply Tracking
RH1612-013	.750-20 UNEF-2A	1.500 (38.100)	3.375 (85.725)	10 ft (3.05m)	TTL Compatible
RH1622-013	.750-20 UNEF-2A	1.500 (38.100)	3.375 (85.725)	10 ft (3.05m)	Supply Tracking
RH1612-014	.750-20 UNEF-2A	2.750 (69.850)	4.625 (117.475)	10 ft (3.05m)	TTL Compatible
RH1622-014	.750-20 UNEF-2A	2.750 (69.850)	4.625 (117.475)	10 ft (3.05m)	Supply Tracking

Net Weight: 9 oz. max.

**Dimensions in inches and (mm).**

## RH Series

### Zero Velocity - Magnetic Hall Effect Sensors - 5/8 and 3/4 Threads

#### Round Body with Connector

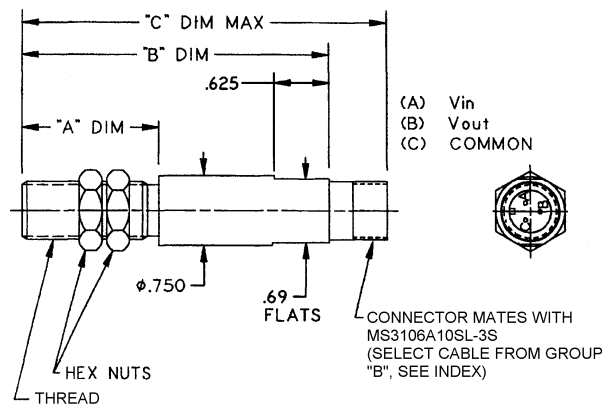

Part Num.	Thread	"A" Dimension	"B" Dimension	"C" Dimension	Output
RH1512-005	.625-18 UNF-2A	1.500 (38.100)	3.375 (85.725)	4.012 (101.905)	TTL Compatible
RH1522-005	.625-18 UNF-2A	1.500 (38.100)	3.375 (85.725)	4.012 (101.905)	Supply Tracking
RH1512-006	.625-18 UNF-2A	2.750 (69.850)	4.625 (117.475)	5.262 (133.655)	TTL Compatible
RH1522-006	.625-18 UNF-2A	2.750 (69.850)	4.625 (117.475)	5.262 (133.655)	Supply Tracking
RH1512-007	.625-18 UNF-2A	4.000 (101.600)	5.875 (149.225)	6.512 (165.405)	TTL Compatible
RH1522-007	.625-18 UNF-2A	4.000 (101.600)	5.875 (149.225)	6.512 (65.405)	Supply Tracking
RH1612-005	.750-20 UNEF-2A	1.500 (38.100)	3.375 (85.725)	4.012 (101.905)	TTL Compatible
RH1622-005	.750-20 UNEF-2A	1.500 (38.100)	3.375 (85.725)	4.012 (101.905)	Supply Tracking
RH1612-006	.750-20 UNEF-2A	2.750 (69.850)	4.625 (117.475)	5.262 (133.655)	TTL Compatible
RH1622-006	.750-20 UNEF-2A	2.750 (69.850)	4.625 (117.475)	5.262 (133.655)	Supply Tracking
RH1612-007	.750-20 UNEF-2A	4.000 (101.600)	5.875 (149.225)	6.512 (165.405)	TTL Compatible
RH1622-007	.750-20 UNEF-2A	4.000 (101.600)	5.875 (149.225)	6.512 (165.405)	Supply Tracking

Net Weight: 7 oz. max.

#### Fully Threaded with Leads

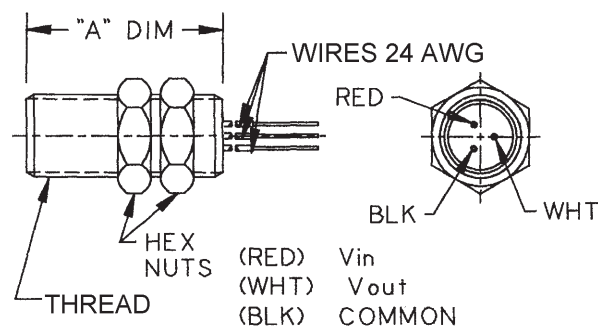

Part Num.	Thread	"A" Dimension	Lead Length	Output
RH1512-009	.625-18 UNF-2A	1.500 (38.100)	12(304)	TTL Compatible
RH1522-009	.625-18 UNF-2A	1.500 (38.100)	12(304)	Supply Tracking
RH1512-010	.625-18 UNF-2A	2.750 (69.850)	12(304)	TTL Compatible
RH1522-010	.625-18 UNF-2A	2.750 (69.850)	12(304)	Supply Tracking
RH1612-009	.750-20 UNEF-2A	1.500 (38.100)	12(304)	TTL Compatible
RH1622-009	.750-20 UNEF-2A	1.500 (38.100)	12(304)	Supply Tracking
RH1612-010	.750-20 UNEF-2A	2.750 (69.850)	12(304)	TTL Compatible
RH1622-010	.750-20 UNEF-2A	2,750 (69.850)	12(304)	Supply Tracking

Net Weight: 3 oz. max.

Dimensions in inches and (mm).

# RH Series Zero Velocity - Magnetic Hall Effect Sensors - 5/8 and 3/4 Threads

## UL/CSA Explosion Proof Sensors

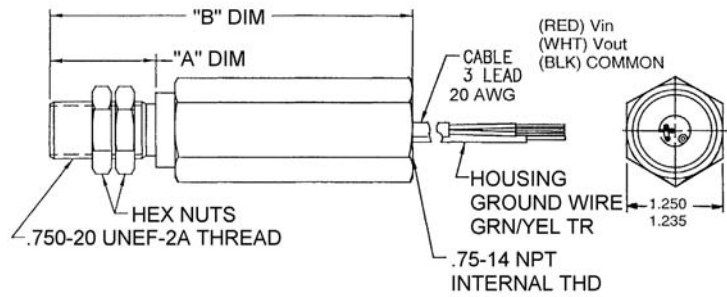

Part Num.	Thread	Thread Length	Overall Length	Cable Length	Output
RH1612-025	.750-20 UNEF-2A	1.375 (34.92)	4.750 (120.65)	10 ft. (3.0 m)	TTL Compatible

Rating: UL & CSA listed for hazardous locations. Class I, Div. 1, Groups A, B, C & D; Class II, Div., 1, Groups E, F & G. Temp Code T4A. Connect only to NEC Class 2 circuits.  
Net Weight: 23 oz. max.

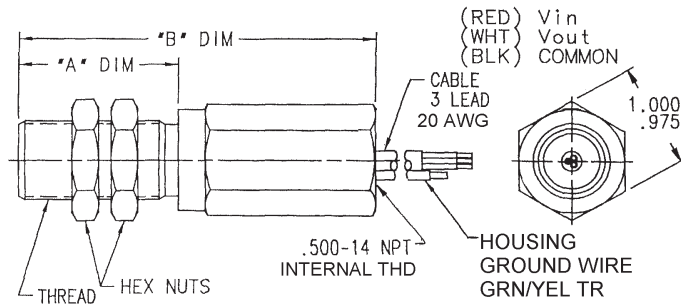

Part Num.	Thread	"A" Dimension	"B" Dimension	Cable Length	Output
RH1512-026	.625-18 UNF-2A	1.500 (38.100)	3.375 (85.725)	10 ft (3.05m)	TTL Compatible
RH1522-026	.625-18 UNF-2A	1.500 (38.100)	3.375 (85.725)	10 ft (3.05m)	Supply Tracking
RH1512-027	.625-18 UNF-2A	2.750 (69.850)	4.625 (117.475)	10 ft (3.05m)	TTL Compatible
RH1522-027	.625-18 UNF-2A	2.750 (69.850)	4.625 (117.475)	10 ft (3.05m)	Supply Tracking
RH1612-026	.750-20 UNEF-2A	1.500 (38.100)	3.375 (85.72.5)	10 ft (3.05m)	TTL Compatible
RH1622-026	.750-20 UNEF-2A	1.500 (38.100)	3.375 (85.725)	10 ft (3.05m)	Supply Tracking
RH1612-027	.750-20 UNEF-2A	2.750 (69.850)	4.625 (117.475)	10 ft (3.05m)	TTL Compatible
RH1622-027	.750-20 UNEF-2A	2.750 (69.850)	4.625 (117.475)	10 ft (3.05m)	Supply Tracking

Rating: UL & CSA listed for hazardous locations. Class I, Div. 1, Groups A, B, C & D; Class II, Div., 1, Groups E, F & G. Temp Code T4A. Connect only to NEC Class 2 circuits.  
Net Weight: 9 oz. max.

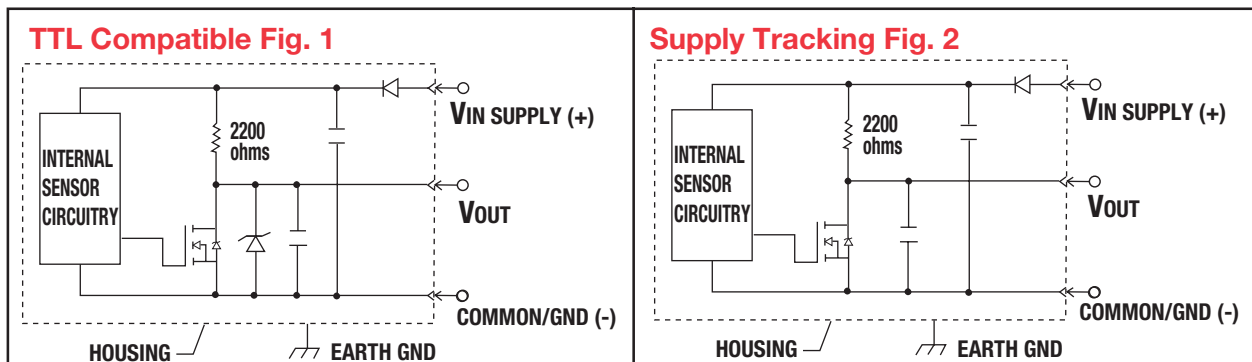

Dimensions in inches and (mm).

# RH Series Zero Velocity - Magnetic Hall Effect Sensors - 3/8 Diameter

## Specifications

### Power Supply

#### Power Supply Voltage:

4.5 - 24 Vdc

#### Power Supply Current:

50 mA maximum

### Outputs

#### Output Voltage:

Essentially square wave fanout to 10 TTL inputs

#### Supply Tracking: (See Figure 1)

50% ±15 % duty cycle

Logic 0: +.6 Vdc maximum

Logic 1:  $V_o = \frac{V_s \times R_L}{R_L + 2.2k}$

#### Output Impedance:

2.2K Ohms ±5%

#### Output Current:

20 mA sink maximum

#### Output Current - Short Circuit:

5 mA maximum with 10V power supply

### Mechanical

#### Target Frequency:

0 to 15 kHz

#### Target Air Gap:

.005 to .015 with a 24 diametral pitch gear

.005 to .025 with a 20 diametral pitch gear

.005 to .050 with a 12 diametral pitch gear

.005 to .065 with an 8 diametral pitch gear

### Environmental

#### Operating Temperature:

-25°C to + 125°C (105°C Cable)

### Materials

#### Housing:

300 series stainless steel

#### Leads:

AWG #24 Teflon, 200°C

#### Cable:

AWG #26 PVC, 105°C

Rotational alignment of sensing face is not required for optimum output signal

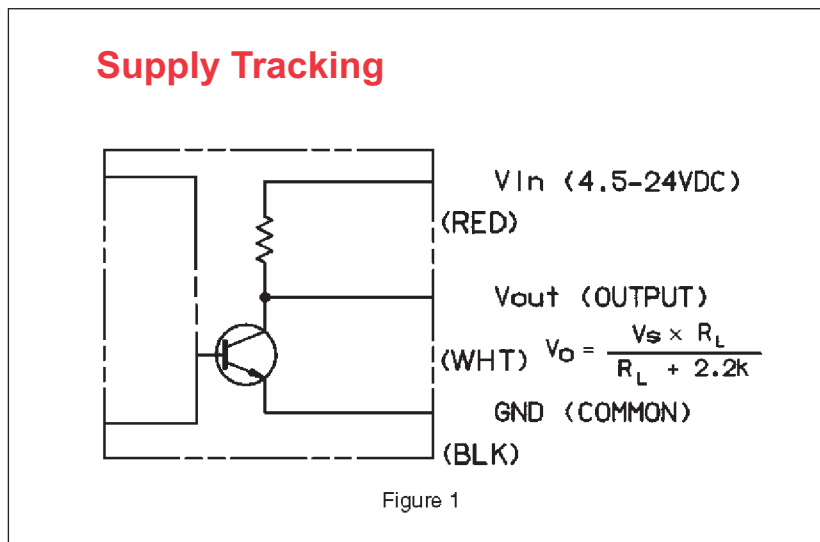

**Note:** Will work with any AI-Tek Tachometer.

# RH Series Zero Velocity - Magnetic Hall Effect Sensors - 3/8 Diameter

## Fully Threaded

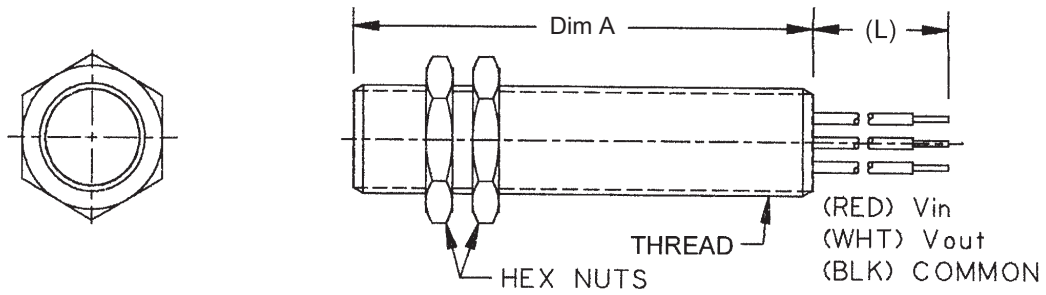

Part Num.	Thread	Cable Length (C)	Lead Length (L)	Dimension A
RH1320-001	.375-32 UNEF-2A	—	12 (304)	1.630
RH1320-003	.375-32 UNEF-2A	10 ft. (3.05 m)	—	1.630
RH1320-009	.375-24 UNF-2A	—	12 (304)	1.630
RH1320-010	.375-24 UNF-2A	10 ft. (3.05 m)	—	1.630
RH1320-012	.375-24 UNF-2A	10 ft. (3.05 m)	—	3.000

New Weight: 0.7 oz. max.

## Round Body

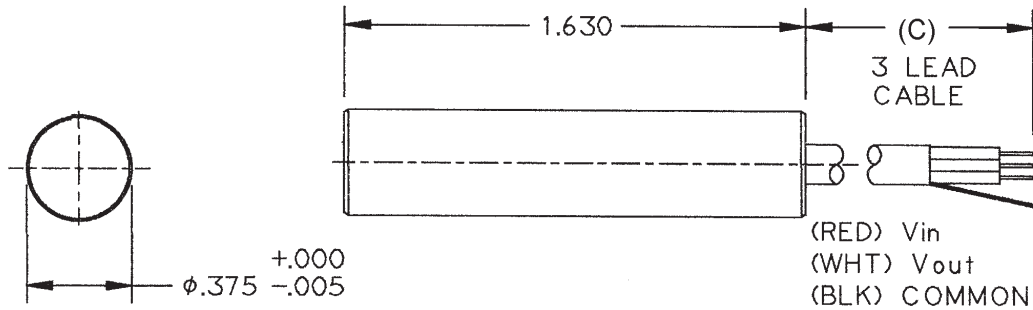

Part Num.	Cable Length (C)	Lead Length (L)
RH1320-005	—	12 (304)
RH1320-006	10 ft. (3.05 m)	—

## DH SERIES

### Zero Velocity - Magnetic Hall Effect Sensors - 5/8 and 3/4 Threads

AI-Tek has taken its years of experience of designing and manufacturing Hall Effect sensors for harsh applications and has developed a line of durable products for industrial, rail, military and automotive use.

The new AI-TEK DH series sensors are differential based, zero-speed, precision, single channel, speed sensors. At power-up, they calibrate themselves to the unique magnetic signature of their installed application and continue to update the calibration as the sensor is running. This unique combination of differential sensing technology and calibration make these sensors highly tolerant of installation mis-alignment, target geometry and composition, target run-out, vibration and air gap changes.

In comparison, the RH series are single-element based, zero speed, single channel speed sensors and are an excellent choice for general purpose speed sensing. Unlike the DH series that requires rotational alignment at installation, the RH requires no alignment. Air gap adjustment is precise and easy and similar to a VR type sensor.

The new DH sensor can sense each change in target movement, regardless of speed, from zero to 15 kHz frequency range, generating a steady pulse train of frequency proportional to target speed. Typically, each time a gear tooth (or any ferrous discontinuity) passes in front of the sensor the output changes state. This type of sensor is known as a "P" type because it uses N-P-N transistor logic (as opposed to "N" type, which uses P-N-P transistor logic).

Key features:

- Reverse voltage protection, to prevent damage if miswired
- Extended temperature range
- Wide range of supply voltage
- Two output options of Supply Tracking or TTL Compatible
- Rugged design meeting IEC 77 Standards (European Railroad Applications)
- Require special alignment
- Improved duty cycle
- Improved fine pitch performance
- Increased air gaps
- Special circuitry provides high level of EM1 hardness
- Select versions equipped with RTD temperature measurement output

Suitable for 32 diametral pitch or coarser gear (target), the standard catalog sensors are easily applied to your various sensing needs. If you have a unique, special requirement which cannot be met with any of the standard options, we will gladly review your specs and work with you on a special sensor design.

*It is the customer's responsibility to determine whether the product is proper for customer's use and application.*



# DH SERIES Zero Velocity - Magnetic Hall Effect Sensors - 5/8 and 3/4 Threads

## Specifications

### Power Supply

**Power Supply Voltage:**

4.5 - 24 Vdc

**Power Supply Current:**

50 mA maximum

### Outputs

**Output Voltage:**

Essentially square wave fanout to 10 TTL inputs

**TTL Compatible:** (See Figure 1)

50% ±10% duty cycle

Logic 0: +.6 Vdc maximum

Logic 1: +4 to +5 Vdc @ 5mA

**Supply Tracking:** (See Figure 2)

50% ±10% duty cycle

Logic 0: +.6 Vdc maximum

Logic 1: 
$$V_O = \frac{V_S \times R_L}{R_L + 2.2k}$$

**Output Impedance:** 2.2K Ohms ±5%

**Output Current:** 20 mA sink maximum

**Output Current - Short Circuit:**

5 mA maximum with 10V power supply

**Reverse Battery Voltage:** -30 Vdc

**Defined Power on State - High**

**Single Tooth/Valley Compatible**

### Mechanical

**Target Frequency:**

0 to 15 kHz

**Target Air Gap:**

.005 to .025 with a 32 diametral pitch gear

.005 to .055 with a 24 diametral pitch gear

.005 to .100 with a 20 diametral pitch gear

.005 to .120 with a 12 diametral pitch gear

.005 to .175 with an 8 diametral pitch gear

**Automatic Calibration:**

Power up +3 edges

Running Update

### Environmental

**Operating Temperature:**

-40°C to +125°C

**Thermal Shock:**

100 cycles air to air (-40° to +130°C)

1 min. ramp time with 30 min. soak

**Salt Spray:**

Per MIL-STD-202, method 201, test cond. B, 5% NaCl for 48 hrs. No visible corrosion

**Humidity:**

92% RH@ 40°C for 90 hrs. No visible corrosion.

**Dielectric Strength:**

Per MIL-STD-202, method 301, 1000 Vrms (60Hz) for 5 sec. leads to case. 1.0 mA max. leakage.

**Insulation Resistance:**

Per MIL-STD-202, method 302, 500 Vdc for 30 sec. leads to case. 100 mega-ohm min.

**Vibration:**

Per MIL-STD-202, resonant frequency search, sine method 204, test cond. C&D (20g); random method 214a, test cond. A&B (7.56g) for 15 min.

**Shock:**

Per MIL-STD-202, method 213b (sawtooth), test cond. H&I (1 00g, 6 ms), 3 shocks, mutually perpendicular planes

### Materials

**Housing:**

300 series stainless steel

**Connector:** MIL Style

Mates with MS3106A10SL-3S

**Leads:** (Available on special request)

AWG #24 Teflon, 200°C

**Cable:**

AWG #20 Irradiated cross-linked polyolefin, 125°C

**Alignment:**

Rotational alignment of sensing face is required for optimum output signal. Align flats with direction of rotation.

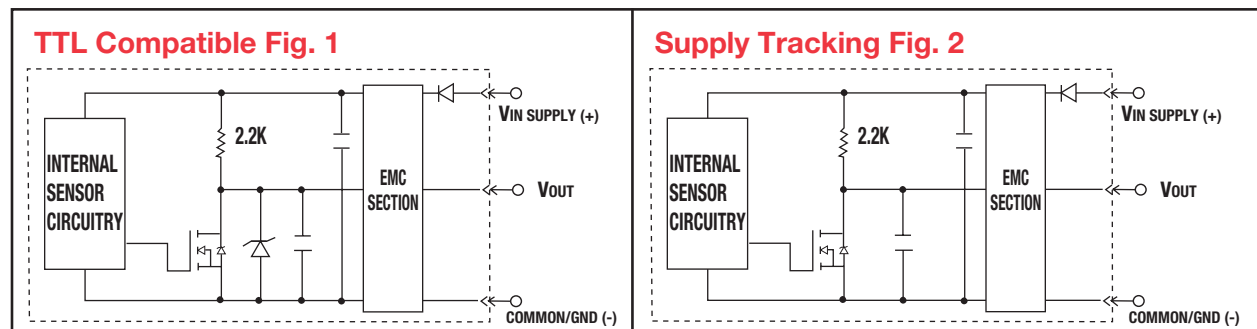

# DH SERIES

## Zero Velocity - Magnetic Hall Effect Sensors - 5/8 and 3/4 Threads

### Hex Body with Cable

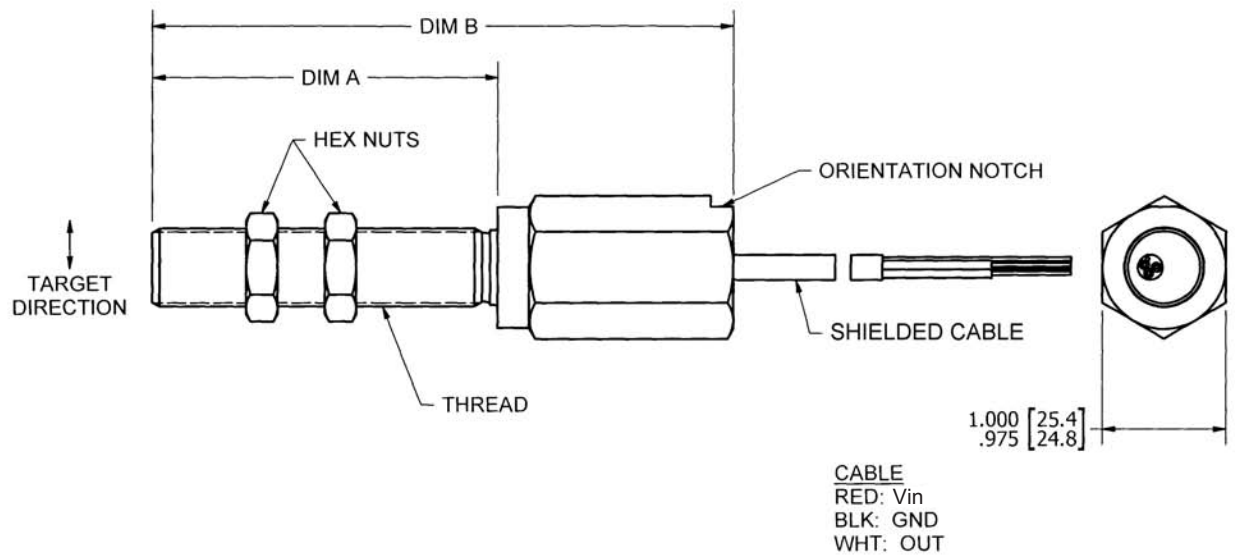

Part Num.	Thread	"A" Dimension	"B" Dimension	Cable Length	Output
DH1512-113	.625-18 UNF-2A	1.500 (38.100)	3.375 (85.725)	10 ft (3.05m)	TTL Compatible
DH1522-113	.625-18 UNF-2A	1.500 (38.100)	3.375 (85.725)	10 ft (3.05m)	Supply Tracking
DH1512-114	.625-18 UNF-2A	2.750 (69.850)	4.625 (117.475)	10 ft (3.05m)	TTL Compatible
DH1522-114	.625-18 UNF-2A	2.750 (69.850)	4.625 (117.475)	10 ft (3.05m)	Supply Tracking
DH1612-113	.750-20 UNEF-2A	1.500 (38.100)	3.375 (85.725)	10 ft (3.05m)	TTL Compatible
DH1622-113	.750-20 UNEF-2A	1.500 (38.100)	3.375 (85.725)	10 ft (3.05m)	Supply Tracking
DH1612-114	.750-20 UNEF-2A	2.750 (69.850)	4.625 (117.475)	10 ft (3.05m)	TTL Compatible
DH1622-114	.750-20 UNEF-2A	2.750 (69.850)	4.625 (117.475)	10 ft (3.05m)	Supply Tracking

Net Weight: 9 oz. max.

*Dimensions in inches and (mm).*

# DH SERIES Zero Velocity - Magnetic Hall Effect Sensors - 5/8 and 3/4 Threads

## Round Body with Connector

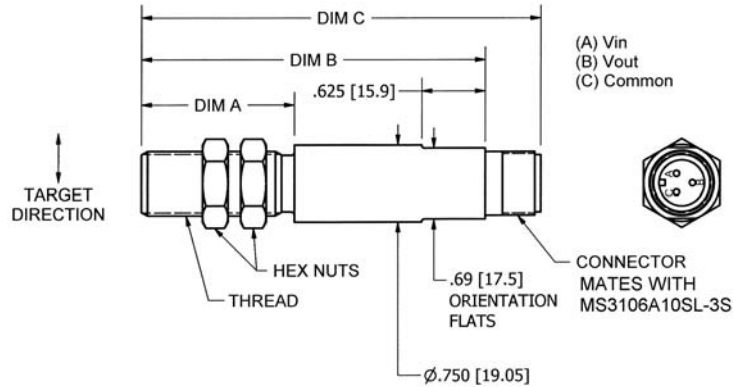

Part Num.	Thread	"A" Dimension	"B" Dimension	"C" Dimension	Output
DH1512-105	.625-18 UNF-2A	1.500 (38.100)	3.375 (85.725)	4.012 (101.905)	TTL Compatible
DH1522-105	.625-18 UNF-2A	1.500 (38.100)	3.375 (85.725)	4.012 (101.905)	Supply Tracking
DH1512-106	.625-18 UNF-2A	2.750 (69.850)	4.625 (117.475)	5.262 (133.655)	TTL Compatible
DH1522-106	.625-18 UNF-2A	2.750 (69.850)	4.625 (117.475)	5.262 (133.655)	Supply Tracking
DH1512-107	.625-18 UNF-2A	4.000 (101.600)	5.875 (149.225)	6.512 (165.405)	TTL Compatible
DH1522-107	.625-18 UNF-2A	4.000 (101.600)	5.875 (149.225)	6.512 (165.405)	Supply Tracking
DH1612-105	.750-20 UNEF-2A	1.500 (38.100)	3.375 (85.725)	4.012 (101.905)	TTL Compatible
DH1622-105	.750-20 UNEF-2A	1.500 (38.100)	3.375 (85.725)	4.012 (101.905)	Supply Tracking
DH1612-106	.750-20 UNEF-2A	2.750 (69.850)	4.625 (117.475)	5.262 (133.655)	TTL Compatible
DH1622-106	.750-20 UNEF-2A	2.750 (69.850)	4.625 (117.475)	5.262 (133.655)	Supply Tracking
DH1612-107	.750-20 UNEF-2A	4.000 (101.600)	5.875 (149.225)	6.512 (165.405)	TTL Compatible
DH1622-107	.750-20 UNEF-2A	4.000 (101.600)	5.875 (149.225)	6.512 (165.405)	Supply Tracking

Net Weight: 7 oz. max.

## Fully Threaded with Leads

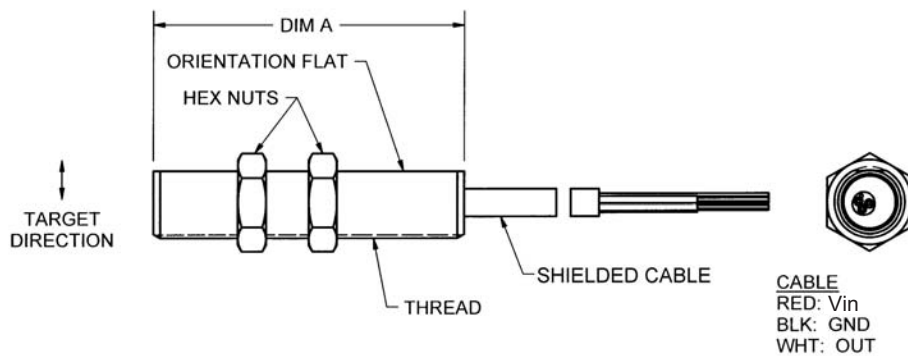

Part Num.	Thread	"A" Dimension	Lead Length	Output
DH1512-109	.625-18 UNF-2A	1.500 (38.100)	12(304)	TTL Compatible
DH1522-109	.625-18 UNF-2A	1.500 (38.100)	12(304)	Supply Tracking
DH1512-110	.625-18 UNF-2A	2.750 (69.850)	10(3.05m)	TTL Compatible
DH1522-110	.625-18 UNF-2A	2.750 (69.850)	10(3.05m)	Supply Tracking
DH1612-109	.750-20 UNEF-2A	1.500 (38.100)	12(304)	TTL Compatible
DH1622-109	.750-20 UNEF-2A	1.500 (38.100)	12(304)	Supply Tracking
DH1612-110	.750-20 UNEF-2A	2.750 (69.850)	12(304)	TTL Compatible
DH1622-110	.750-20 UNEF-2A	2.750 (69.850)	12(304)	Supply Tracking

Net Weight: 3 oz. max.

# DH SERIES

## Zero Velocity - Magnetic Hall Effect Sensors - 5/8 Threads

Fully Threaded with Cable and Temperature Output

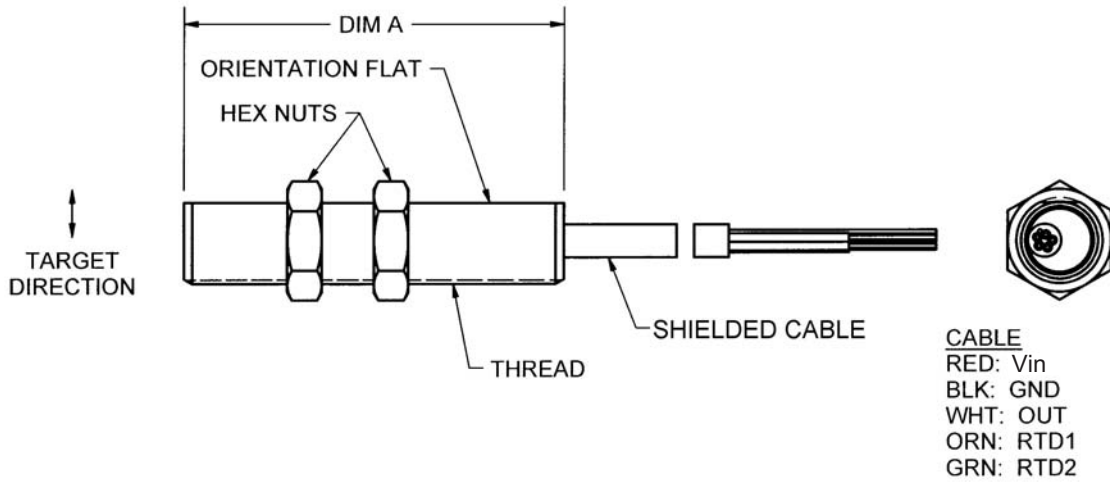

Part Num.	Thread	"A" Dimension	Lead Length	Output
DH1512-210	.625-18 UNF-2A	2.750 (69.850)	10(3.05m)	TTL Compatible
DH1522-210	.625-18 UNF-2A	2.750 (69.850)	10(3.05m)	Supply Tracking

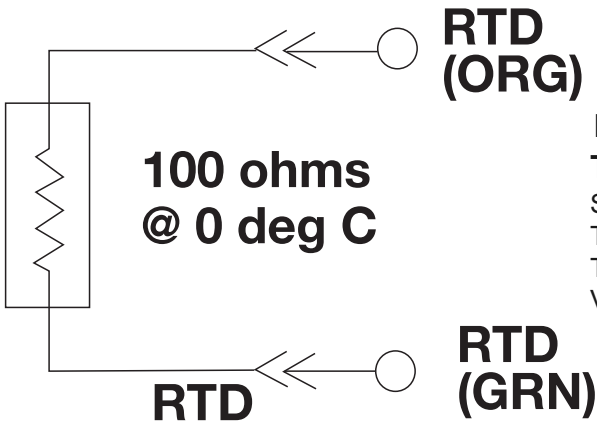

**RTD TEMPERATURE SENSOR:**  
 Sensor Resistance: 0°C = 100 Ω in air  
 Temp coefficient (0°C - 100°C) = 0.00385 Ω/Ω/°C (AVE)  
 $T = [(R/100-1) \times 259.740^\circ\text{C} \pm 1.5^\circ\text{C}]$   
 $V_{\text{max}} = 1 \text{ vdc} / I_{\text{max}} = 1.0\text{mA}$

## **BH SERIES**

### **Bi-Directional, Dual Channel, Magnetic Hall Effect Speed Sensors - 5/8 and 3/4 Threads**

**AI-Tek** Bi-directional, zero velocity sensors are self-calibrating to the specific customer application and provide two independent frequency outputs and a direction signal output to indicate change in direction of the sensed, ferrous target.

The Bi-directional sensor can also be referred to as a dual channel sensor since it utilizes two Hall effect sensing elements, physically offset from each other. Each element generates a single channel of target information, identical in frequency and polarity, but offset in the time domain (phase shifted). Special circuits inside the sensor are designed to calibrate each channel to its application target, then analyze these two channels of information for a phase lead / lag condition. The direction output will then provide a logic 1 level for clockwise or a logic 0 for counterclockwise rotation, assuming proper sensor orientation.

For applications that exceed 500 Ft (150 meters) go to page 42 for the DSDA, (Digital Signal Distance Amplifier).

*It is the customer's responsibility to determine whether the product is proper for customer's use and application.*

## BH SERIES

### Active Sensor (Bi-Dir.) Selection Guide

Thread Size	Part Number	Supply Tracking or TTL	Termination	Thread Length (in)	Sensor Length (in)	Page
3/4-20	BH1612-001	TTL	Connector	1.5	3.375	40
3/4-20	BH1622-001	ST	Connector	1.5	3.375	40
3/4-20	BH1612-002	TTL	Connector	2.75	4.625	40
3/4-20	BH1622-002	ST	Connector	2.75	4.625	40
3/4-20	BH1612-013	TTL	Cable	1.5	3.375	40
3/4-20	BH1622-013	ST	Cable	1.5	3.375	40
3/4-20	BH1612-014	TTL	Cable	2.75	4.625	40
3/4-20	BH1622-014	ST	Cable	2.75	4.625	40
3/4-20	BH1612-005	TTL	Connector	1.5	3.375	41
3/4-20	BH1622-005	ST	Connector	1.5	3.375	41
3/4-20	BH1612-006	TTL	Connector	2.75	4.625	41
3/4-20	BH1622-006	ST	Connector	2.75	4.625	41
3/4-20	BH1612-009	TTL	Cable	4	4	41
3/4-20	BH1622-009	ST	Cable	4	4	41
3/4-20	BH1612-010	TTL	Cable	6	6	41
3/4-20	BH1622-010	ST	Cable	6	6	41
5/8-18	BH1512-001	TTL	Connector	1.5	3.375	40
5/8-18	BH1522-001	ST	Connector	1.5	3.375	40
5/8-18	BH1512-002	TTL	Connector	2.75	4.625	40
5/8-18	BH1522-002	ST	Connector	2.75	4.625	40
5/8-18	BH1512-013	TTL	Cable	1.5	3.375	40
5/8-18	BH1522-013	ST	Cable	1.5	3.375	40
5/8-18	BH1512-014	TTL	Cable	2.75	4.625	40
5/8-18	BH1522-014	ST	Cable	2.75	4.625	40
5/8-18	BH1512-005	TTL	Connector	1.5	3.375	41
5/8-18	BH1522-005	ST	Connector	1.5	3.375	41
5/8-18	BH1512-006	TTL	Connector	2.75	4.625	41
5/8-18	BH1522-006	ST	Connector	2.75	4.625	41
5/8-18	BH1512-009	TTL	Cable	4	4	41
5/8-18	BH1522-009	ST	Cable	4	4	41
5/8-18	BH1512-010	TTL	Cable	6	6	41
5/8-18	BH1522-010	ST	Cable	6	6	41

## BH SERIES

# Bi-Directional, Dual Channel, Magnetic Hall Effect Speed Sensors - 5/8 and 3/4 Threads

## Specifications

### Power Supply

**Power Supply Voltage:** 10 - 28 Vdc

### Power Supply Current:

100 mA maximum

### Outputs

#### Output Voltage:

Essentially square wave fanout to 10 TTL inputs

**TTL Compatible:** (See Figure 1)

40% to 60% duty cycle

Logic 0: +.6 Vdc maximum

Logic 1: +4 to +5.0 Vdc @ 5mA

**Supply Tracking:** (See Figure 2)

40% to 60% duty cycle

Logic 0: +.6 Vdc maximum

Logic 1:  $V_O = \frac{V_S \times R_L}{R_L + 2.2k}$

#### Direction Logic:

Output high (Logic 1) with rotation toward notch

**Output Impedance:** 2.2K Ohms  $\pm$ 5%

#### Output Current:

20 mA sink max., 1.0 mA source max.

**Reverse Battery Voltage:** -30 Vdc

**Rise/Fall Time:** 5  $\mu$ s / 3  $\mu$ s typical

## Mechanical

**Target Frequency:** 0 to 15 kHz

### Target Performance:

DIAMETRICAL PITCH	AIRGAP RANGE (Inches)
8	.051 - .160
10	.020 - .140
12	.010 - .120
20	.010 - .100
24	.005 - .050
32	.005 - .040

## Environmental

### Operating Temperature:

-40°C to +125°C

### Thermal Shock:

100 cycles air to air (-40° to +130°C)

1 min. ramp time with 30 min. soak

### Salt Spray:

Per MIL-STD-202, method 201, test cond. B, 5% NaCl for 48 hrs. No visible corrosion

### Humidity:

92% RH@ 40°C for 90 hrs. No visible corrosion.

### Dielectric Strength:

Per MIL-STD-202, method 301, 1000 Vrms (60Hz) for 5 sec. leads to case. 1.0 mA max. leakage.

### Insulation Resistance:

Per MIL-STD-202, method 302, 500 Vdc for 30 sec. leads to case. 100 mega-ohm min.

### Vibration:

Per MIL-STD-202, resonant frequency search, sine method 204, test cond. C&D (20g); random method 214a, test cond. A&B (7.56g) for 15 min.

### Shock:

Per MIL-STD-202, method 213b (sawtooth), test cond. H&I (100g, 6 ms), 3 shocks, mutually perpendicular planes

### EMC:

Design principles consistent with BS/EN and MIL-STD's for EMC hardness

## Materials

### Housing:

300 series stainless steel

### Cable:

AWG #22 Irradiated cross-linked polyolefin, 125°C, 5 lead wires

### Channel phasing: 45° to 135°

Sensor must be aligned. Target rotation toward notch/flat results in Logic 1 direction output.

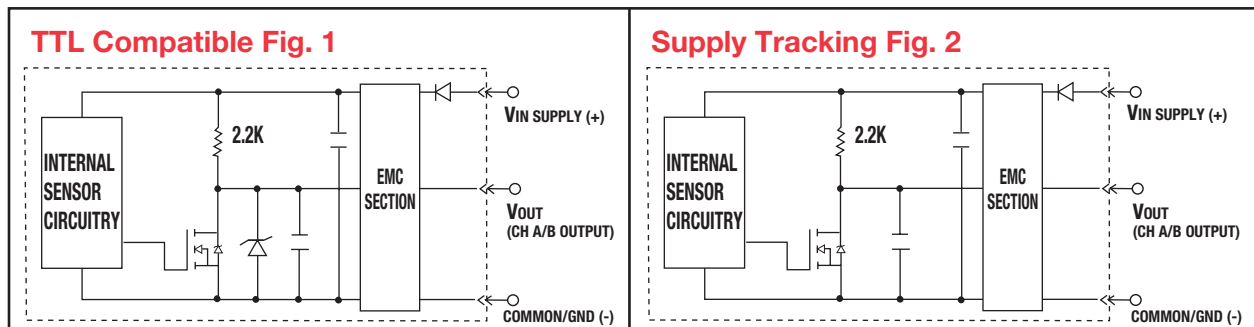

Note: Either output will work with any AI-Tek Tachometer.

## BH SERIES

### Bi-Directional, Dual Channel, Magnetic Hall Effect Speed Sensors - 5/8 and 3/4 Threads

#### Bi-Directional, Hex Body with 6 Pin Connector

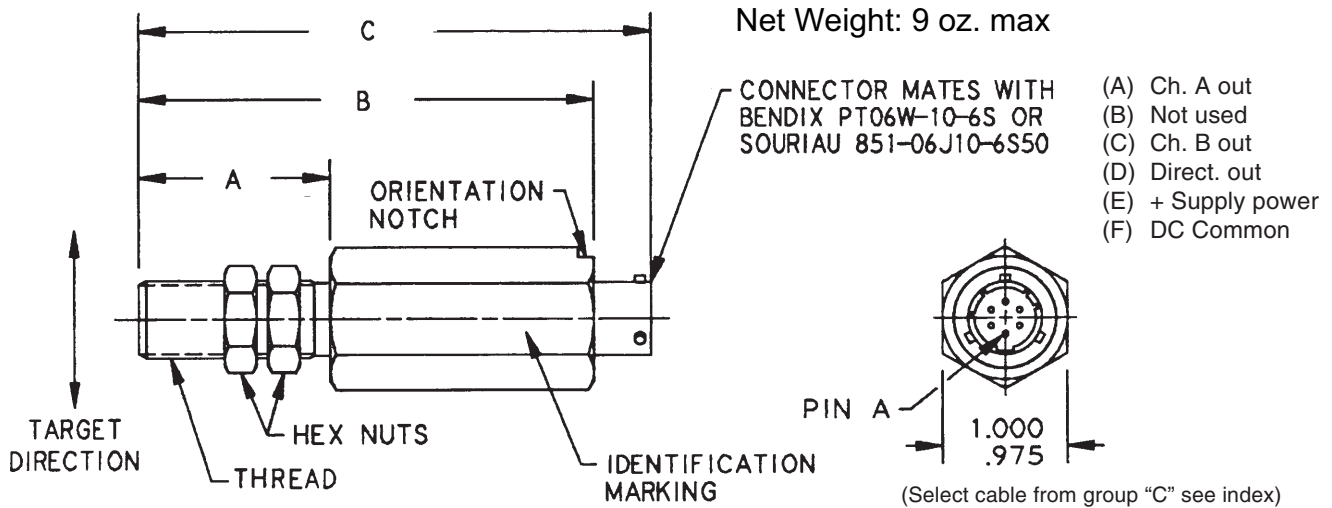

Part Num.	Thread	"A" Dim.	"B" Dim.	"C" Dim. (max.)	Output
BH1512-001	.625-18UNF-2A	1.500 (38.1)	3.375 (85.7)	3.875 (98.4)	TTL Compatible
BH1522-001					Supply Tracking
BH1512-002		2.750 (69.9)	4.625 (117.5)	5.125 (130.2)	TTL Compatible
BH1522-002					Supply Tracking
BH1612-001	.750-20UNEF-2A	1.500 (38.1)	3.375 (85.7)	3.875 (98.4)	TTL Compatible
BH1622-001					Supply Tracking
BH1612-002		2.750 (69.9)	4.625 (117.5)	5.125 (130.2)	TTL Compatible
BH1622-002					Supply Tracking

#### Bi-Directional, Hex Body with Cable

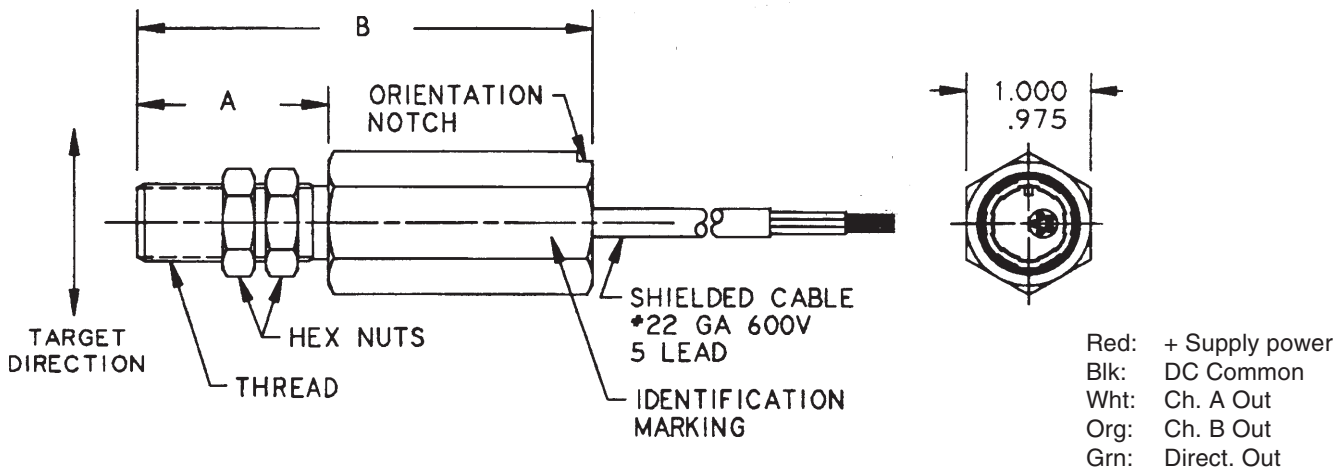

Part Num.	Thread	"A" Dim.	"B" Dim.	Cable Length	Output
BH1512-013	.625-18UNF-2A	1.500 (38.1)	3.375 (85.7)	10 ft. (3.05m)	TTL Compatible
BH1522-013					Supply Tracking
BH1512-014		2.750 (69.9)	4.625 (117.5)		TTL Compatible
BH1522-014					Supply Tracking
BH1612-013	.750-20UNEF-2A	1.500 (38.1)	3.375 (85.7)	10 ft. (3.05m)	TTL Compatible
BH1622-013					Supply Tracking
BH1612-014		2.750 (69.9)	4.625 (117.5)		TTL Compatible
BH1622-014					Supply Tracking



# BH SERIES

## Bi-Directional, Dual Channel, Magnetic Hall Effect Speed Sensors - 5/8 and 3/4 Threads

### Bi-Directional, Round Body with Connector

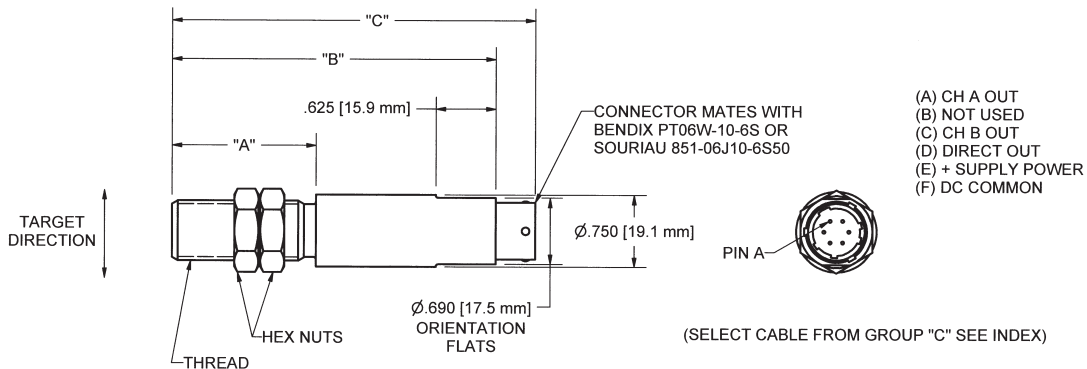

Part Num.	Thread	"A" Dim.	"B" Dim.	"C" Dim. (max.)	Output
BH1512-005	.625-18 UNF-2A	1.500 (38.1)	3.375 (85.7)	3.875 (98.4)	TTL Compatible
BH1522-005					Supply Tracking
BH1512-006		2.750 (69.9)	4.625 (117.5)	5.125 (130.2)	TTL Compatible
BH1522-006					Supply Tracking
BH1612-005	.750-20 UNEF-2A	1.500 (38.1)	3.375 (85.7)	3.875 (98.4)	TTL Compatible
BH1622-005					Supply Tracking
BH1612-006		2.750 (69.9)	4.625 (117.5)	5.125 (130.2)	TTL Compatible
BH1622-006					Supply Tracking

Net Weight: 6 oz. max

### Bi-Directional, Fully Threaded with Cable

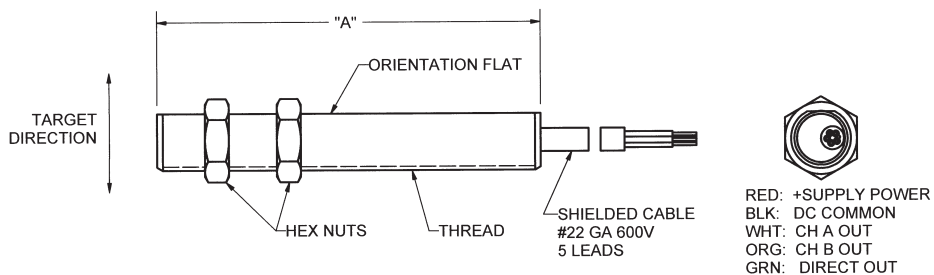

Part Num.	Thread	"A" Dim.	Cable Length	Output
BH1512-009	.625-18 UNF-2A	4.000 (101.6)	10 ft. (3.05m)	TTL Compatible
BH1522-009				Supply Tracking
BH1512-010		6.000 (152.4)		TTL Compatible
BH1522-010				Supply Tracking
BH1612-009	.750-20 UNEF-2A	4.000 (101.6)	10 ft. (3.05m)	TTL Compatible
BH1622-009				Supply Tracking
BH1612-010		6.000 (152.4)		TTL Compatible
BH1622-010				Supply Tracking

Net Weight: 11 oz. max

Dimensions in inches and (mm).

## Digital Signal Distance Amplifier (DSDA)

The newest member of the AI-Tek family.

The new AI-TEK DSDA's are designed for use with active sensors and serve to reduce line impedance, allowing cable runs of up to 3000ft. In some cases this represents a 10X improvement over installations not currently using a DSDA.



Line impedance plays a major role in the distance an active sensor signal can be transmitted through cable and wire. Mutual capacitance of 25 Pico-farads/foot or more can exist between conductors. When sufficient resistance from the sensor, cabling and output load is placed in series with that capacitance signal rise times can increase to the point where the sensor can no longer switch. This condition becomes even worse due to higher target speeds that cause output signal frequency rises

Two versions were developed to allow use with either TTL or supply tracking output options. The DSDA will work with any AI-TEK active sensor and many other brands that support these output styles.

Construction is rugged. Each DSDA is potted into a cast aluminum box. Cables enter the box through weather-tight strain relief bushings and allow all cable connections, including shield, to be terminated inside the box.

	EA79880-100 TTL**	EA79880-200 SUPPLY TRACKING
INPUT POWER	8 – 24 VDC	4.5 – 18 VDC
SIGNAL INPUT	2.4 – 18 VDC	3.5 – 18 VDC
OUTPUT SIGNAL: Logic 1	3.5 – 5.5 VDC	4.5 – 18 VDC
Logic 0	0.6 VDC max	0.6 VDC max.
OUTPUT CURRENT	100mA max	100mA max
LOAD IMPEDANCE	240 $\Omega$ min.	240 $\Omega$ min.
OUTPUT CABLE LENGTH	Up to 3000ft* (914 m)	Up to 3000ft* (914 m)

*\*Maximum cable length dependent on wiring practices, cable or wire type and specifications, load specifications, and signal frequency. Keep capacitance, resistance and inductance as low as possible to maximize cable run.*

\*\* For TTL applications using 5V input power use EA79880-200

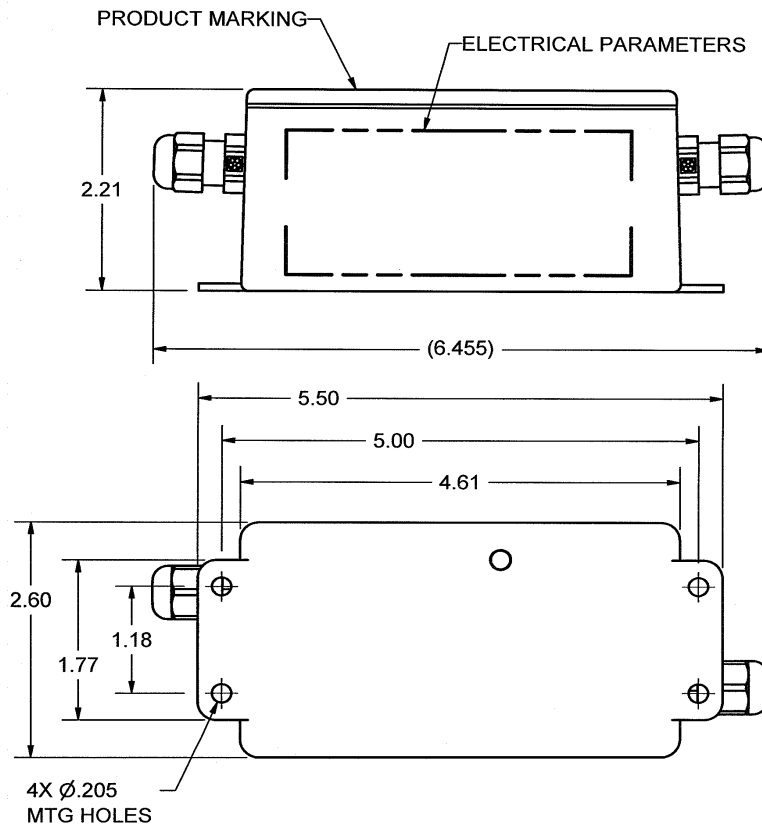

## Connectors and Cable Assemblies

AI-Tek stocks a selection of connectors and cable assemblies for your convenience. For ease of selection, the connectors and assemblies are divided into groups. Group "A" is designed for 2-wire items, Group "B" for 3-wire and Group "C" for 5-wire.

Complete cable assemblies include the connector and 10' of recommended wiring for use with AI-Tek equipment. All wiring is insulated, and wrapped with braided or copper shield and jacketed in long-lasting PVC, Teflon or polyolefin insulation. Alternate cable length is 50', use -050 for final suffix.



Group		A-I Tek P/N	Mil. Connect. No.	Max. Temp.	Cable Wiring
A	S	CN79860 -3100	MS3106A10SL-4S	125°C	Connector Only
	R	-3800	MS3108B10SL-4S	125°C	Connector Only
	S	-3000	MS3456L10SL-4S	175°C	Connector Only
	S	CA79860 -01-010	MS3106A10SL-4S	105°C	2 #22 Black & White
	R	-17-010	MS3108B10SL-4S	105°C	2 #22 Black & White
	S	-06-010	MS3456L10SL-4S	175°C	2 #20 Black & White
B	S	CN79860 -2600	MS3106A10SL-3S	125°C	Connector Only
	R	-3900	MS3108B10SL-3S	125°C	Connector Only
	S	CA79860 -18-010	MS3106A10SL-3S	125°C	3 #20 Red, White & Black
	R	-24-010	MS3108B10SL-3S	125°C	3 #20 Red, White & Black
C	S	CN79860 -4200	MIL-C-26482	125°C	Connector Only
	S	CA79860-30-010	PT06W-10-6S Bayonet Style	125°C	5#22 Red, Orange, Black, White, Green

Net Weight: 5 oz. max.

Standard cable assemblies include 10ft. of shielded cable. Special length cables may be available for 50 pcs or more.

S = Straight Connector  
R = Right Angle Connector

*It is the customer's responsibility to determine whether the product is proper for customer's use and application.*

**Groups A & B (Straight)**

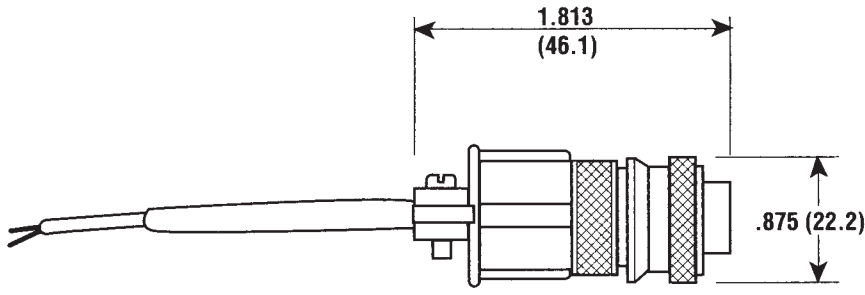

**Group A Pins**

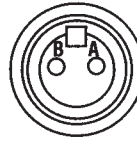

**Group A**  
 PIN A = Black  
 PIN B = White

**Groups A & B (Right Angle)**

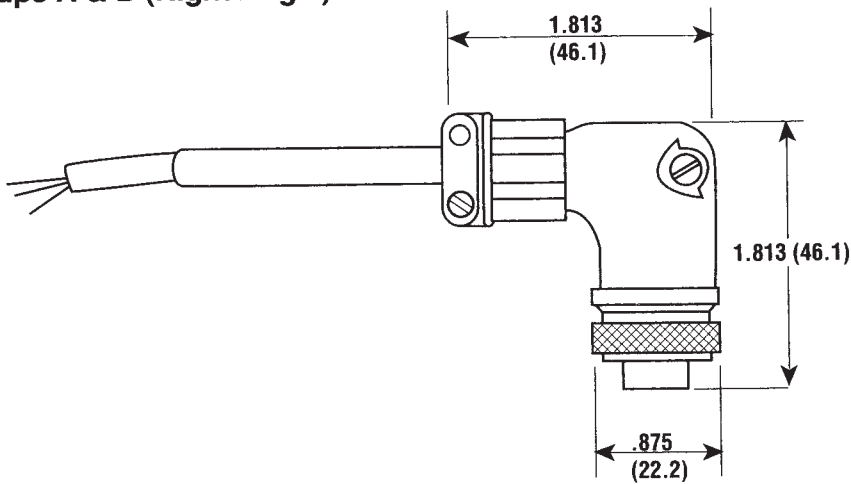

**Group B Pins**

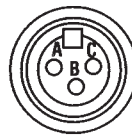

**Group B**  
 PIN A = Red  
 PIN B = White  
 PIN C = Black

**Group C**

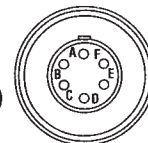
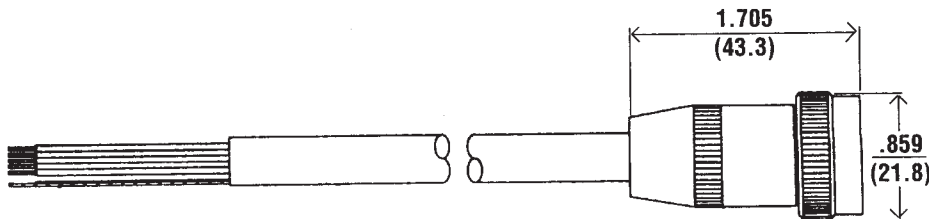

**Group C**  
 PIN A = White  
 PIN B = Not Used  
 PIN C = Orange  
 PIN D = Green  
 PIN E = Red  
 PIN F = Black

## Split Gears

When using an AI-Tek speed sensor in RPM measurement, split gears provide a convenient and simple means of installation where shaft disassembly is not feasible. The two halves of the gear are fastened with clamping screws, thus assuring close fit. All split gears are 12 diametral pitch, 14.5° pressure angle.

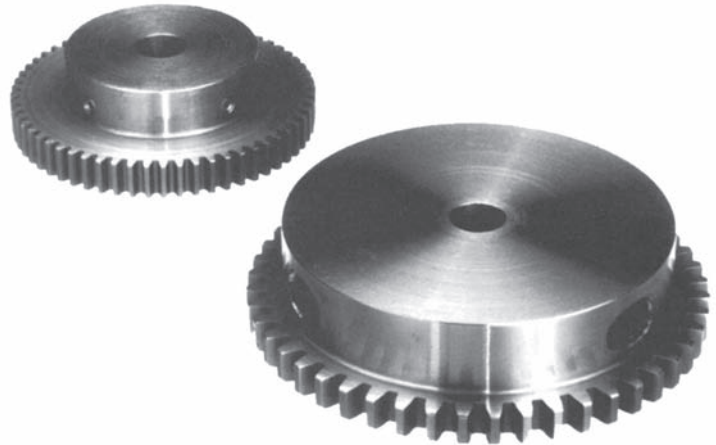

## Solid Gear

AI-Tek also offers a 20 diametral pitch, 14.5° pressure angle, solid steel gear. This gear can be rebored to fit shaft diameters up to 1.375". It is secured to the shaft with 2 set screws.

**Note:** Gears are supplied with minimum bores as shown. Alternate bores within the minimum and maximum limits are available at additional cost.

**Caution:** Gears may shatter if not installed to specifications or if operated above maximum RPM.

Dimensions of Steel Split Gears									
Part No.	Pitch Dia., In.	O.D. Inches	No. of Teeth	Tooth Face, In.	Overall Length, In.	Std. Bore Dia., In.	Max. Bore Dia., In.	Approx. Wt., Lbs.	Max. RPM
G79870-202-1800	4.000	4.166	48	.312	1.000	0.500	2.125	3.0	8400
G79870-202-1901	5.000	5.166	60	.312	1.000	1.000	3.125	5.0	5900
G79870-202-2001	6.000	6.166	72	.312	1.000	1.000	4.000	7.0	5900
G79870-202-2101	8.000	8.166	96	.312	1.125	1.000	5.750	15.0	4500
G79870-202-2201	10.000	10.166	120	.312	1.250	1.000	7.500	26.0	3000
G79870-202-4233	15.000	15.166	180	.375	1.375	7.500	12.000	48.0	2400
Dimensions of Solid Steel Gear									
G79870-202-0967	3.000	3.100	60	.375	0.875	0.375	1.375	1.2	6000

## Steel Split Gear

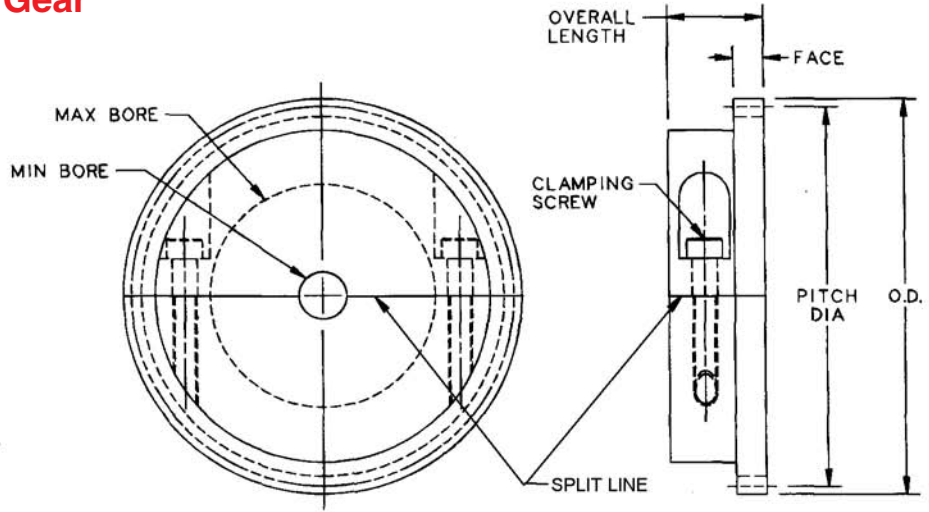

## Solid Steel Gear

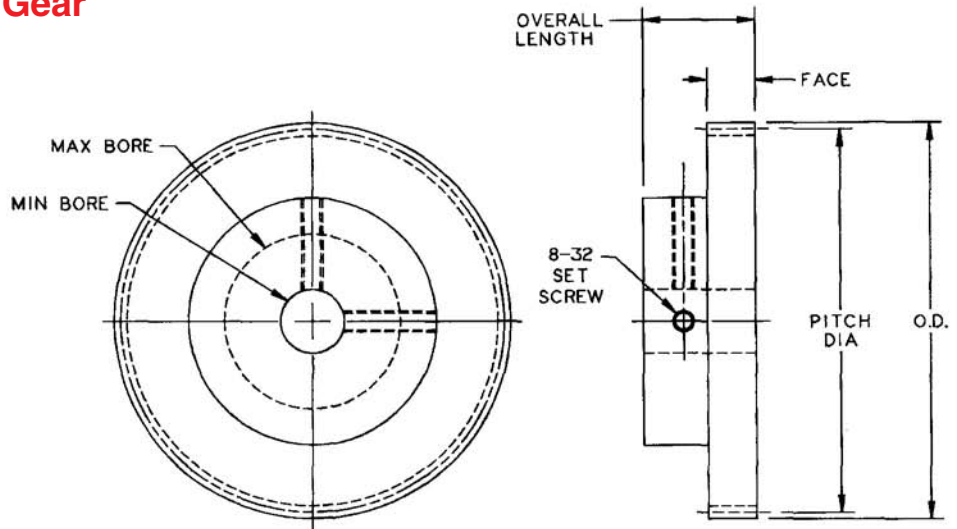



## Tachometer Transducers

**AI-Tek** tachometer transducers are self-generating units when used with speed sensors. They are designed primarily to provide an easy means of attaching a pulse generating assembly to rotating shafts. Sensor gapping, shaft run-out and mounting problems are eliminated. This makes the unit especially useful for shafts with high run-out. The ordering map on the following page provides information for selecting a unit for your particular application. Please note that sensors and cable assemblies must be ordered separately.

### Taper-Lock® Type

The assembly consists of a Taper-Lock bushing which enables quick attachment to rotating shafts. The transducer employs a rotor with small perforations along its periphery; a permanently lubricated sealed bearing; an outer ring and a reference rod which, when clamped in position, prevents the outer ring assembly from moving. The outer ring can accommodate up to three speed sensors for use in monitoring directions of rotation and speed.

### Sleeve Type

The **AI-Tek** sleeve-type transducer assembly is identical to the Taper-Lock type except that it provides a sleeve bushing with two set screws for installation purposes, allowing larger shaft sizes.

## Mechanical Specifications

*Lubrication:* Bearings are permanently lubricated; do not use pressure washes or solvents.

*Finish:* Reference rod and outer ring are anodized aluminum.

*Reference Rod:* 1/4" diameter, 6" long

*Bearing Limits:* 4000 RPM max. speed

*Weight:* 54 oz. (1.53 kg) max.

*Sensor Mounting:* 5/8-18 UNF-2A threaded hole std.

## Electrical Specifications

*Output Frequency:* 30 pulses/rev. (1 Hz = 2RPM), Standard; 60 pulses/rev. (1 Hz = 1RPM), Optional.

*Output Voltage:* Depends on magnetic sensor used. One turn of sensor controls 0.056 inches of air gap based on 5/8-18 UNF-2A thread. Normal gap setting range from 0.005 to 0.020 inches.

*Ambient Temperature:* -30°C to +50°C

**NOTE:** *Not for use in abrasive atmospheres.*

*It is the customer's responsibility to determine whether the product is proper for customer's use and application.*



## Ease of Installation

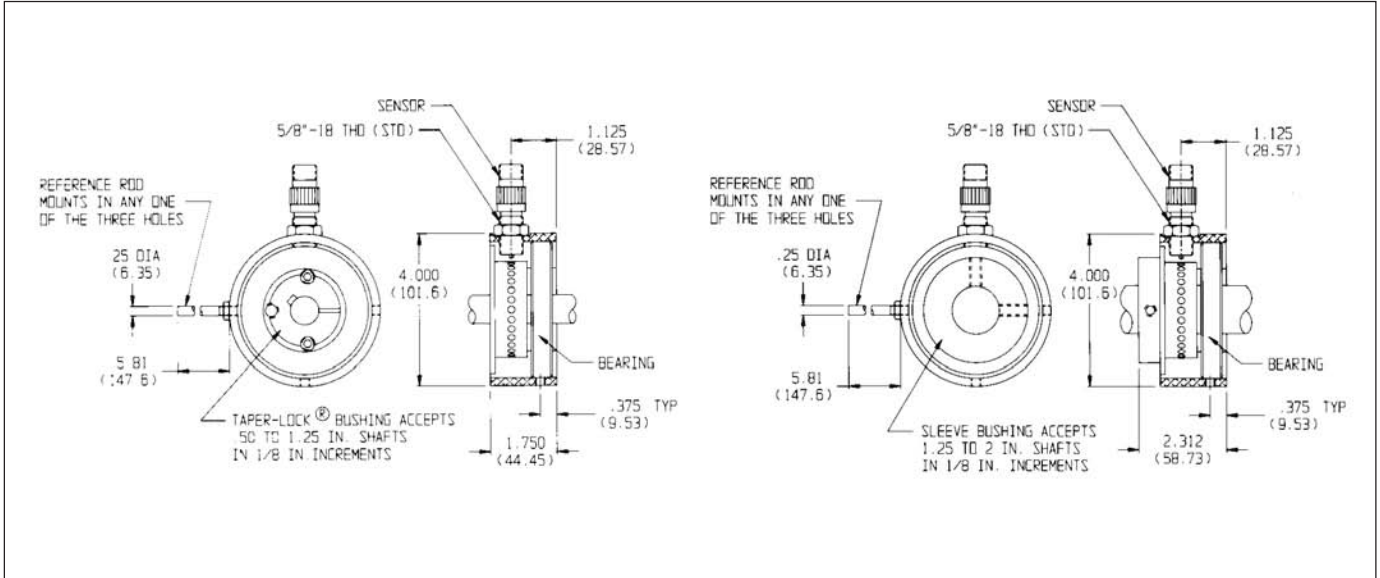

## Ordering Map

T79850-103-

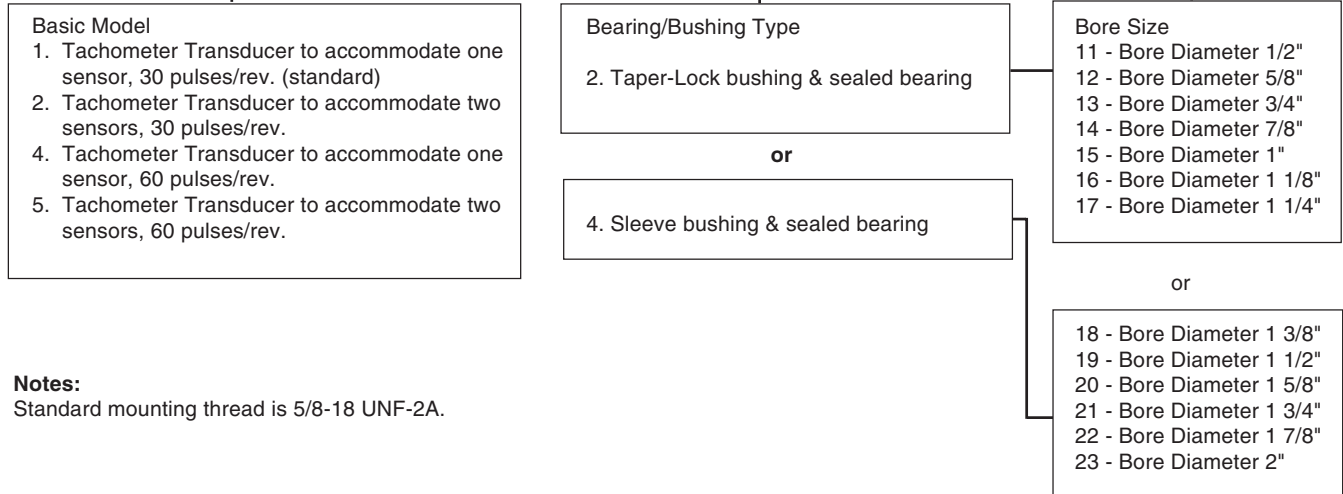

### Notes:

Standard mounting thread is 5/8-18 UNF-2A.

## Ordering Procedure

**Example:** Speed indicating system for a variable speed motor, 0 - 1750 RPM, 1" shaft diameter, panel-mount display within 10 ft., min. motor speed is 175 RPM.

1. Select Model No. **T79850 - 103 - 1215**  
 30 PPR, std. basic model    
 Taper-lock, sealed bearing  1" bore dia.

2. Select a speed sensor such as P/N 70085-1010-001
3. Select a cable assembly, P/N CA79860-01-00, to complement (2).
4. Select tachometer to meet application needs.

**Dimensions in inches and (mm).**

## Sensor Mounting Brackets

Several types of brackets are available to facilitate the mounting of AI-Tek speed sensors. Threaded brackets for 3/8-24, 5/8-18 and 3/4-20 threads are generally used with passive sensors with one locknut. Active, zero-velocity sensors and passive, chisel-point sensors that require specific alignment should be used with unthreaded brackets and two locknuts.

Bracket material is non-magnetic, 303 stainless steel; locknuts are also non-magnetic stainless steel or plated brass.

Sensors and brackets should be attached to a frame free of excessive vibration to prevent spurious indications when the gear is stopped or turning at very slow speeds. Refer to sensor specifications for proper air gap and alignment with gear (target) rotation.

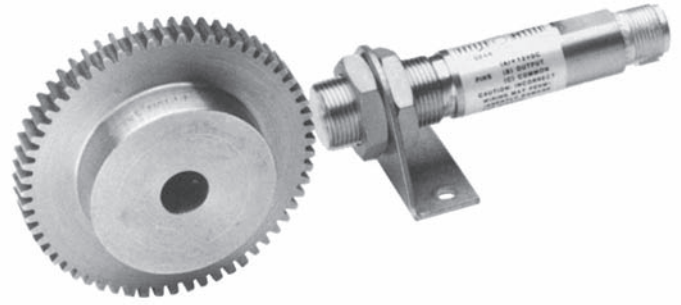

**Caution:** Too small an air gap, especially with excessive run-out, may cause the gear to strike the sensor and make it inoperative.

Threaded Brackets		
Thread Size	Bracket Part No.	One Turn Advances
3/8-24 UNF-2B	646-310-0006	.042"
5/8-18 UNF-2B	646-310-0007	.056"
3/4-20 UNEF-2B	646-310-0008	.050"

Net Weight: 4 oz. max.

Unthreaded Brackets		
Thread Size Of Sensor	Hole Diameter	Bracket Part No.
3/8-24 UNF-2A	.390"	646-140-0009
5/8-18 UNF-2A	.640"	646-140-0010
3/4-20 UNEF-2A	.765"	646-140-0015

Net Weight: 2 oz. max.

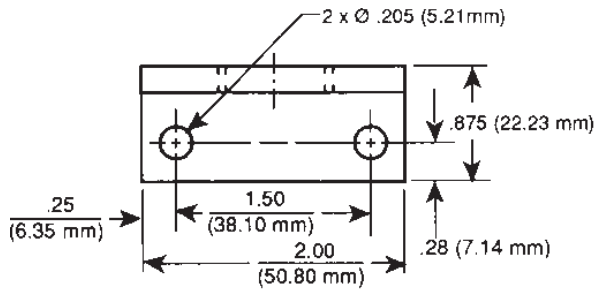

Threaded Bracket

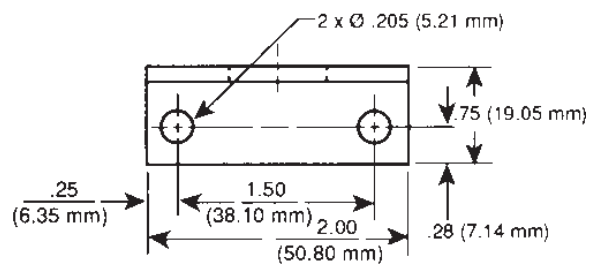

Unthreaded Bracket

Dimensions in inches and (mm).

## Principles of Operation

The internal construction of the typical **AI-Tek** variable reluctance sensor is a magnet, pole piece and coil (See figure 1). A magnetic field (lines of flux) extends from the magnet, through the pole piece and coil out into the air space at the end of the sensor. The return path of the magnetic field is from the air space to the other end of the magnet. As a ferrous object approaches the tip of the pole piece, the magnetic field increases and then decreases as the object moves away from the pole piece. The snap or the rapid change in the magnetic field induces an AC voltage signal in the coil. With an ideal target and matching sensor, the induced voltage is in the shape of a sine wave.

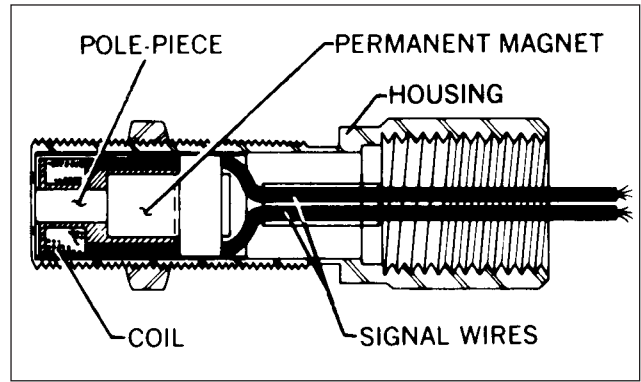

Figure 1 - Internal configuration of typical sensors.

As can be seen, the generated frequency signal is directly proportional to the number of ferrous objects passing the pole piece per unit time. The amplitude of the voltage output is proportional to the speed of the ferrous objects passing the pole piece.

Many applications of **AI-Tek** magnetic sensors use gears as targets. Typical sensor output wave forms with various targets are illustrated in Figure 3. Testing sensors with gears rather than other ferrous discontinuities such as sprockets, keyways, boltheads, etc. is because the output is predictable and repeatable. See Figure 2 for commonly used gear terminology.

$$\text{Diametral Pitch} = \frac{\text{No. of Teeth} + 2}{\text{Outside Dia. of Gear (in.)}}$$

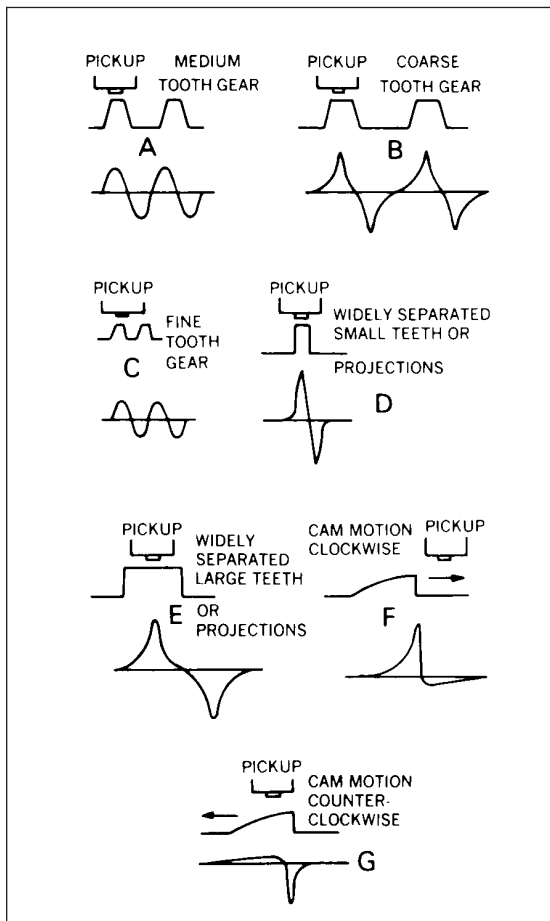

Figure 3 - Generated voltage waveforms.

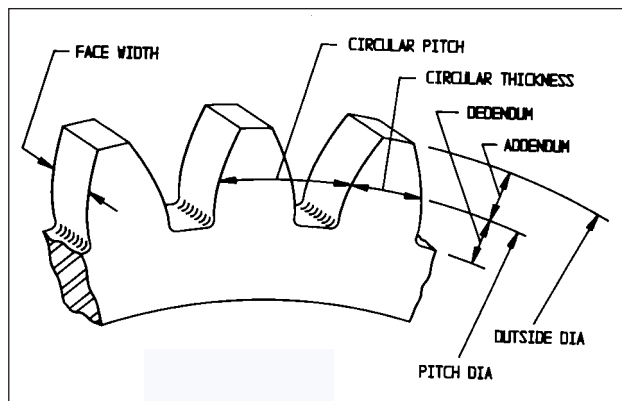

Figure 2 - Common terms used in defining gears.

The performance of a sensor can be easily defined when using a gear for a target; it also allows for estimated performance with alternate targets. **AI-Tek** sensors are tested with AGMA standard gears; the performance curves are included in this catalog.

**AI-Tek Instruments** differs from most sensor manufacturers in the presentation of performance curves and test parameters. Most existing data is specified at a surface speed of 1000 in/sec and 0.005 in. air gap; we feel that a 0.030 in. air gap and 500 in. sec. surface speed (1800 RPM motor with 5 to 6 in. dia. gear) are more realistic parameters to specify performance.

## PART NUMBER INDEX

Part Number	Page	Part Number	Page
<b>Passive Sensors</b>			
70084-1713-111 .....	11	<b>IEC EX</b>	
70085-1010-001 .....	8	70085-3030-111 .....	20
70085-1010-002 .....	8	70085-3030-112 .....	20
70085-1010-003 .....	8	70085-3030-113 .....	20
70085-1010-004 .....	9	70085-3030-114 .....	20
70085-1010-005 .....	18	70085-3030-211 .....	20
70085-1010-007 .....	13	70085-3030-212 .....	20
70085-1010-018 .....	8	70085-3030-213 .....	20
70085-1010-024 .....	16	70085-3030-214 .....	20
70085-1010-026 .....	8	70085-3030-222 .....	20
70085-1010-028 .....	9	70085-3030-235 .....	20
70085-1010-037 .....	17	70085-3030-237 .....	20
70085-1010-041 .....	14	70085-8080-001 .....	15
70085-1010-056 .....	13	70085-8080-003 .....	11
70085-1010-078 .....	10	70085-8080-004 .....	15
70085-1010-081 .....	18	Side Look Sensor .....	21
70085-1010-086 .....	13		
70085-1010-118 .....	8	<b>Single Channel Hall Effect Sensors</b>	
70085-1010-120 .....	15	RH Series .....	23-31
70085-1010-131 .....	10	DH Series .....	32-36
70085-1010-137 .....	10		
70085-1010-174 .....	14	<b>Bi-Directional Hall Effect Sensors</b>	
70085-1010-175 .....	8	BH Series .....	37-41
70085-1010-182 .....	17	Digital Signal Distance Amplifier .....	42
70085-1010-214 .....	10		
70085-1010-220 .....	11	<b>Connectors and Cable Assemblies</b>	
70085-1010-227 .....	16	CA79860-01-XXX .....	44
70085-1010-289 .....	17		
70085-1010-299 .....	17	<b>Gears</b>	
70085-1010-314 .....	15	G79870-202-XXXX .....	46
70085-1010-327 .....	18		
70085-1010-328 .....	18	<b>Transducers</b>	
70085-1010-329 .....	18	T79850-103-XXXX .....	48
70085-1010-330 .....	18		
70085-1010-355 .....	13	<b>Brackets</b>	
70085-1010-403 .....	19	646-XXX-XXXX .....	50
70085-1010-404 .....	19		
70085-1010-405 .....	19		
70085-1010-406 .....	19		
70085-1010-408 .....	8		
70085-1010-411 .....	18		
70085-1010-412 .....	18		
70085-1010-413 .....	18		
70085-1010-414 .....	18		
70085-1010-415 .....	19		
70085-1010-416 .....	19		
70085-1010-417 .....	19		
70085-1010-420 .....	19		
70085-1010-421 .....	12		
70085-1010-424 .....	12		
70085-1010-425 .....	12		
70085-1010-428 .....	14		
70085-1010-458 .....	14		
70085-1010-469 .....	9		
70085-1010-472 .....	16		
70085-1010-540 .....	19		
70085-1010-541 .....	19		
70085-1010-542 .....	19		
70085-1010-543 .....	19		
70085-1010-544 .....	19		